

SWMD BOARD PACKET



PREPARED FOR
Board of Commissioners
PREPARED BY
Cammie Henderson



South Walton Mosquito District

Regular Board Meeting Agenda

 Thursday, May 21, 2026 — 10:00 AM

 SWCMCD Headquarters

774 N County Hwy 393, Santa Rosa Beach, FL 32459

Call to Order

- Chair to state time.

Invocation & Pledge of Allegiance

Approval of Minutes

- April 23, 2026 — Regular Board Meeting (*Motion*) – Page 5

Public Comment (Non-Agenda Items)

Departmental Updates:

Construction Update – Page 11

- Administration Building — status report
- Phase II — status report
- Chicken Coop – status report
- DAG – Add Services – Page 18
 - Phase I (*Motion*)
 - Phase II (*Motion*)

Administration Report – Page 77

- Financial Report
- Expenditures (*Motion*) — Request to receive and forward for CPA review – Page 98

Legal

- Invoice (*Motion*) – Page 105

Operations

- Summary & Lab Report — updates from field and lab – *Page 111*
-

Commissioner Report

- **Seat 1:** Doug Liles
 - **Seat 2:** Steve Young
 - Mission:
Serve the District:
Protect the public from disease carrying mosquitoes
Suppress mosquito populations in the safest and most economic manner
Minimize impact to people, wildlife and the environment
 - Vision:
Utilize science, technology and performance metrics to deliver the highest standard of mosquito control services with regard to Public Health, Environmental Stewards and efficient use of taxpayer dollars.
 - **Seat 3:** Kristine Faulk
-

Current Action Items

Opened	Item	Action	Due Date	Close Date
07/2025	Add QR codes on trucks linking to the public info site	Kellyanne is currently updating the complete website	Apr 2026	
10/2025	Resolution on Website	Kellyanne is updating the website.	Apr 2026	
02/2026	Financial Process – Financial Review Quarterly		Apr 2026	
03/2026	Create a timeline from Wharton-Smith/DAG		May 2026	

Future Action Items

Opened	Item	Action	Due Date	Close Date
03/2026	Review and create a letter for the County		June 2026	
11/2025	Evaluate sidewalk – stormwater	Chairman Doug Liles – Increased impermeable area may increase flooding.	July 2026	
11/2025	Joint-Use Agreement for Emergency Use		Jan 2027	
04/2026	AI Policy Review	Create policy	July 2026	
04/2026	Payroll Outsource	Look for alternatives	Aug 2026	
04/2026	Accounting Software	Research what other districts are using.	Aug 2026	
04/2026	Brand	Create a brand to show public health, environmental stewards, and fiscally responsible	Aug 2026	

New Business

Comments by Commission and Public

Adjournment

- Request Motion to adjourn (*state time*)
-

Next Scheduled Meeting

 **Thursday, June 25, 2026 — 10:00 AM**

 **SWCMCD Headquarters**



South Walton County Mosquito Control District
2025-2026 Regular Board Meeting
Thursday, April 23, 2026 – 10:00 AM
Minutes of Meeting

The Board of Commissioners of the South Walton County Mosquito Control District held its Regular Board Meeting at the District Office at 774 North Highway 393, Santa Rosa Beach, Florida, on April 23, 2026, at 10:00 AM.

Chairman Doug Liles called the meeting to order on April 23rd at 10:00 AM and opened with a Prayer and Pledge of Allegiance to the American Flag.

The Commissioners attending the meeting were Doug Liles, Steve Young, and Kristine Faulk. Attorney Amy Myers participated in the meeting.

Staff Present: Darrin Dunwald, Director
 Cammie Henderson, Finance & HR Manager
 Gerry Williams, Operations Manager

APPROVAL OF MINUTES

March 19, 2026, Regular Board Meeting
Request a motion to approve the March Regular Board Meeting.
Motion by: Commissioner Kriss Faulk
Second by: Commissioner Steve Young
Motion approved: 3-0

PUBLIC COMMENT - NON-AGENDA ITEMS – None

CONSTRUCTION UPDATE

Phase I
Working on the punch list. Back porch coated. Front porch next week. Discussion ensued.

Phase II
Parking garage looks good.
Waiting on CO for parking garage.

Chicken Coop
Pouring footers. Discussion ensued.

DAG – Add Services (motion)
Phase I – DAG \$70,412.00 – O’Connell \$41,100.00
Discussion ensued. The commissioner would like to table until hours spent, and the change orders breakdown can be provided by DAG.
O’Connell – additional time for administration. Separate Phase I and Phase II.
Tabled until next meeting.
Phase II
Tabled until next month.

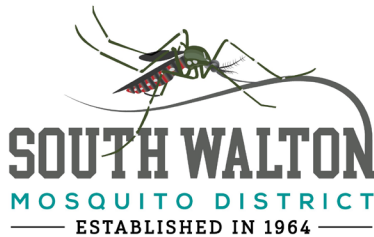

ADMINISTRATIONS REPORT

Financial Report for March

Discussion ensued.

Expenditures for March (Motion)

Request a motion to receive the March expenditure as presented for CPA review.

Motion by: Commissioner Steve Young

Second by: Commissioner Kriss Faulk

Motion approved: 3-0

LEGAL

March Invoices (Motion) – no invoice

OPERATIONS

March Summary with Lab Report – Discussion ensued

Moving the ditch. Amy Myers doesn't believe we are liable for the ditch.

PUBLIC OUTREACH

Quarterly Update discussion ensued.

Simplify the website.

URL – to link to the operations page.

COMMISSIONERS

Seat – 1 Doug Liles – AI policy – designate that you are using AI with your policies.

Seat – 2 Steve Young

Accounting system software review – August 2026

- This project will compare our QuickBooks system to those used by the larger FMCA members

- Comparison lists benefits, risks, and costs

- Reason for the project is to address our QuickBooks ' potential for fraud because it does not let you lock down accounting after a month is closed

Outsource payroll – August 2026

- This project will compare the benefits, risks, and costs of outsourcing payroll
- Current process is to perform payroll function internally

AI (Artificial Intelligence) policy – July 2026

- This project will create an AI policy for our district

- Obtain AI policies from the larger FMCA members and other sources to create a policy

- Once a policy is created, obtain Board member input

- Create a referendum for Board member approval

- Current status: we don't have an AI policy



South Walton County Mosquito Control District
 2025-2026 Regular Board Meeting
 Thursday, April 23, 2026 – 10:00 AM

South Walton Mosquito District (SWMD) Brand – August 2026

- This project will create a guide for the SWMD Brand
- Suggested brands are Public Health, Environmental Steward, and Fiscally Responsible with Taxpayer Money
 - All marketing material and social media posts will support and promote our brand
 - Create an approval process for all marketing material and posts to be approved by a staff member, like Cammie or Gerry, then our director, Darrin, before it is published
 - This year's Annual Report will describe how SWMD fulfills each component of our brand
 - It's worthwhile noting our Mission and Vision are aligned with the Brand

Seat – 3 Kristine Faulk – None

ADDITIONAL NON-AGENDA ITEMS –

Current Action Items

Opened	Item	Action	Due Date	Close Date
07/2025	Add QR codes on trucks linking to the public info site	Kellyanne is currently updating the complete website	Apr 2026	
10/2025	Resolution on Website	Kellyanne is updating the website.	Apr 2026	
10/2025	Review commissioner travel expenses (past 2 years)		Apr 2026	April 2026
02/2026	Financial Process – Financial Review Quarterly		Apr 2026	

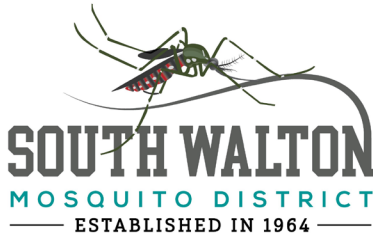

South Walton County Mosquito Control District
 2025-2026 Regular Board Meeting
 Thursday, April 23, 2026 – 10:00 AM

Future Action Items

Opened	Item	Action	Due Date	Close Date
03/2026	Create a timeline from Wharton-Smith/DAG		May 2026	
03/2026	Review and create a letter for the County		June 2026	
11/2025	Evaluate sidewalk – stormwater	Chairman Doug Liles – Increased impermeable area may increase flooding.	July 2026	
11/2025	Joint-Use Agreement for Emergency Use		Jan 2027	

New Business

Opened	Item	Action	Due Date	Close Date
04/2026	AI Policy Review	Create policy	07/2026	
04/2026	Payroll Outsource	Look for alternatives	08/2026	
04/2026	Accounting Software	Research what other districts are using.	08/2026	
04/2026	Brand	Create a brand to show public health, environmental stewards, and fiscally responsible	08/2026	



South Walton County Mosquito Control District
2025-2026 Regular Board Meeting
Thursday, April 23, 2026 – 10:00 AM

COMMENTS BY COMMISSION AND PUBLIC – None

Request for motion to Adjourn by Chairperson Doug Liles

Motion by: Commissioner Kristine Faulk

Second by: Commissioner Steve Young

Motion approved: 3-0

Chairperson Doug Liles adjourned the meeting at 11:30 AM.

Chairperson Doug Liles: _____

Commissioner Kristine Faulk: _____

Commissioner Steve Young: _____

CONSTRUCTION UPDATE





SOUTH WALTON COUNTY MOSQUITO CONTROL DISTRICT
Phase 2 – Parking Garage & Fleet Maintenance
24-189
OAC Meeting #15 Agenda
5/5/26
Next OAC Meeting Tuesday 5/19 at 10:00 AM

Safety/Security:

- No safety incidents/ accidents to date (242 days).
- Scaffolding work.
- Overhead steel work and welding.
- Safety Week Lunch, 5/7 @ 11:30.

Schedule Updates:

- Fleet Maintenance:
 - Bocci – Column and beam install is in-progress.
 - Reyco – CMU install is in-progress.
 - Bright Future – Electrical rough-in is in-progress.
 - Bell Steel – Mezzanine steel install is in-progress.

Submittals:

- Fleet Maintenance:
 - 069.2210.002 – SSE – Plumbing Fixture (PD) Re-Submittal - Sent 4/20
 - 106.7400.000 – Kent – Roof System Drawings – Sent 4/30
 - 107.9000.000 – Universal Coatings – Coatings Product Data – Sent 5/4

RFIs:

- 097- FM – Door Schedule and Access Control Conflict – Sent 4/28
- 098 - FM – West Porch Fans Confirmation – Sent 4/30
- 099 - FM – Duct Type Clarification – Sent 5/4

Design & Permitting:

- Parking Garage CO Inspection 5/6.
- Updates to details and sections needed.

Project Financials:

- CO-07 submitted to DAG, 4/30.
- Pay Application #12 for April submitted to Owner, 4/30.
- TCR-12 submitted to DAG, 5/4.

Open Discussion/New Business:

- Chicken Coop metal building install next week.



ATTENDEES:

NAME	COMPANY	EMAIL	Call-in (C) / Present (P)
Darrin Dunwald	SWCMCD – Director	ddunwald@swcmcd.org	P
Gerry Williams	SWCMCD – Operations Manager	gwilliams@swcmcd.org	P
Cammie Henderson	SWCMCD – Office Manager	chenderson@swcmcd.org	
Pat Ballasch	DAG - Architect	pballasch@dagarchitects.com	
Steven Nicholson	DAG – Architect PM	snicholson@dagarchitects.com	P
Keith Johnson	Watford – Mechanical EOR	keith@whatfordengineering.com	
Ian Bernander	Watford – Mechanical Designer	ianb@watford-engineering.com	C
Jon Nash	O’Connell – Civil EOR	jon@oconnellengineers.com	
Alex London	O’Connell – Civil Project Engineer	alex@oconnellengineers.com	
Michael Ekblad	O’Connell – VP Landscaping	Michael@oconnellengineers.com	
Jason Albano	Wharton-Smith – Project Executive	jalbano@whartonsmith.com	C
Langley Dickeson	Wharton-Smith – Project Manager	ldickeson@whartonsmith.com	P
Daniel McCutcheon	Wharton-Smith – Asst. Project Manager	dmccutcheon@whartonsmith.com	P
Phil Ward	Wharton-Smith – Superintendent	gward@whartonsmith.com	P
Kelley Royball	Wharton-Smith – Superintendent	kroyball@whartonsmith.com	P
Cameron Pastorius	HG – Project Engineer	cpastorius@hgenineers.com	C
Tyson Sanders	O’Connell – Project Engineer	tyson@oconnellengineers.com	
Rick Engle	HG – Electrical EOR	rengle@hgenineers.com	

SWCMCD HQ PH2 Parking Garage and Fleet Maintenance









13 May 2026

South Walton Mosquito Control District
c/o Darrin Dunwald
774 N. Highway 393
Santa Rosa Beach, FL 32459

RE: Add service request for South Walton Mosquito Control District HQ

Darrin,

We are submitting this request to address cost overruns incurred during the Construction Administration phase of the Administration Building.

It is important to note that this request is not an effort to adjust our fee proportionally to the increased construction budget. Rather, we are seeking compensation solely to address the additional time and resources required to deliver CA services beyond what was originally anticipated, and to bring our compensation back in line with the effort expended. This effort included DAG and O’Connell & Associates, which both were affected by the extended duration of time as well as the plan revisions, field modifications, contractor coordination and preparation of details associated with the construction changes.

A summary of CA service phase performance is as follows:

DAG Service Order #4: CA	Budgeted \$59,589.00 Spent \$130,001.00	\$70,412.00 of additional effort in this phase.
O’Connell CA Duration & Revisions	See attached Add Services Letter to this proposal	\$41,100.00 of additional effort in this phase.

CA services were based on a 12-month construction schedule. Our CA efforts for the Administration Building commenced on **07/15/2024** and were finalized on **2/05/2026**, totaling **17-months**. This extended time was necessary to support the project and required our additional effort to see the project to the finish line to ensure the District received the quality product it deserves.

Below is a list of additional details needed to remedy in field conflicts caused by deficiencies in construction and a lack of quality performance of subcontractors or owner driven changes. In addition, we had to ramp up our presence on site from once every two weeks to weekly site visits to ensure quality control. See **Exhibit C** attached to this letter showing a breakdown of hours needed to accomplish this task.

Additional Details and Supplemental Instructions: See attached Exhibit B

1. ASI #2 - Coordinate requested Data/Telecom to be added to Rooms (002,005,008,017,018,025,026) – See attached
2. ASI #8 - New TV locations per Owner Request – See attached
3. ASI #9 - Front Porch Slab Control joint layout and Demo Plan – See attached
4. SK – 5 Kneewall – Framer did not frame walls continuous up to bottom of trusses – See attached
DAG had to coordinate detail and execution.

5. Boardroom lighting layout – Sub installed light fixtures crooked and not spaced properly
6. ASI #12 – Stair and Railing – Sub did not install monolithic stair correctly for designed railing.
7. ASI #16 – West Elevation and Wall Section – Sub did not install hardie panel trim per the Elevations. Ship lap had to be demoed, and an enlarged detail was provided for proper installation.
8. ASI #17 - New rain chain detail and basin detail needed to remedy roof overhang
9. ASI #18 – North downspout Section - North Roof and planter wall/sidewalk conflict – redesign of rain chains & downspouts was required to connect to storm water.

We remain committed to the successful completion of Phase 2 and continue to provide the necessary level of service to support the project. This request is intended to fairly reconcile the discrepancy between the original fee assumptions and the actual time and effort required.

We appreciate your consideration and are available to discuss this request in further detail.

I. Compensation

The fee for these additional services is as follows:

Description	Amount
DAG Add Service	\$70,412.00
O’Connell	\$41,100.00
Total Add Service	\$111,512.00

**Additional bookkeeping and support is available upon request.*

II. Conclusion

If you accept the Lump Sum Fee described above for the Additional Services, please provide your signature below.

Accepted By:

[Signature]

[Printed Name and Title]

We appreciate the opportunity to continue supporting this project and for your trust in our team.

Sincerely,



Pat Ballasch, AIA
President, DAG Architects

Attachments (as applicable):

- Exhibit A – O’Connell & Associates Additional Services Letter
- Exhibit B - Additional Detail and Supplemental Instructions
- Exhibit C – DAG Construction Administration Hours Budgeted and Spent Breakdown

EXHIBIT A

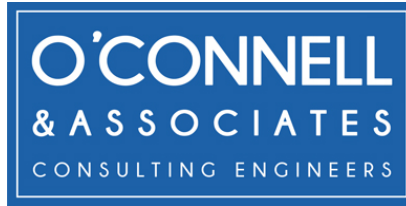

May 8, 2026

DAG Architects
c/o Mr. Pat Ballasch
1223 Airport Road
Destin, Florida 32541

RE: South Walton Mosquito Control District
Campus Upgrade Project – Phase II
Additional Services – Contract Administration

Mr. Ballasch,

The purpose of this Additional Services Agreement (ASA) is to address additional Contract Administration services required during construction that were not included in our original Professional Engineering Services Proposal dated September 6, 2024. These additional services are associated with an extended construction duration and additional plan revisions, construction exhibits, and coordination services required during the construction phase of the project.

As outlined in our original proposal, Contract Administration services were included for a limited construction duration and level of effort. Since that time, the construction schedule has been extended, and additional engineering services have been required to support plan revisions, field modifications, contractor coordination, and preparation of exhibits and details associated with construction-related changes and coordination with Walton County and the project team.

These additional services are reflected in this Additional Services Proposal for your review and authorization. Please let us know if you have any questions or require further clarification.

Based on our understanding of the project, we propose to perform the following tasks as our Scope of Work:

CONTRACT ADMINISTRATION – CONSTRUCTION DURATION EXTENSION: \$14,400.00

1. The original Construction Administration scope was developed based on an anticipated 12-month construction schedule; however, the project duration has since extended to 16 months to date. As a result of this schedule and other unforeseen factors that have led to additional effort, the original budget for these services has been fully utilized. This additional scope provides Contract Administration services from the present date through the anticipated completion of construction in December 2026. Services to be provided include coordination with the Owner and Contractor, progress meetings, as-built drawing review, permit closeout services, site visits, and general construction phase coordination services.

Attached to this proposal as **Exhibit A** is a breakdown of the time and costs associated with contract administration services rendered to date. These services include both remaining Phase 1 efforts and ongoing Phase 2 construction administration services. Due to the requirements and conditions of the State and Local permits, Phase 1 services cannot be fully completed until Phase 2 construction is complete, as final certification and project closeout are contingent upon completion of the overall project.

The fee for these services is based on an anticipated average of \$1,600 per month of contract administration services for the remaining construction duration through December 2026.

CONTRACT ADMINISTRATION – CONSTRUCTION PLAN REVISIONS: \$26,700.00

1. Provide additional Contract Administration services associated with construction-related plan modifications, coordination drawings, and preparation of miscellaneous exhibits and details required during construction. These services include, but are not limited to, the following:

<p>A. PHASE 1 – Plan Revisions, & Misc. Exhibits (Item #1 on Exhibit B) Administration Building:</p> <ol style="list-style-type: none"> 1. Exhibits and details for bridge area modification at central mosquito ditch crossing. 2. Enhanced Landscape design for the project entry sign. 3. Utility plan modifications to include new water service on the west side of the project. 4. Parking lot revisions resulting from misplaced light pole. 5. Landscape plan modifications and Walton County deviation request regarding landscape buffers. 6. Pedestrian bridge sidewalk modifications. 7. Building downspout and sidewalk revisions.
<p>B. PHASE 2 – Plan Revisions & Misc. Exhibits (Item #7 on Exhibit B) Fleet Garage:</p> <ol style="list-style-type: none"> 1. Revision to the building footprint prior to initial Development Order submittal. 2. Revision prior to Development Order issuance to add downspouts and bollards and revise domestic water layout. <p>Fleet Maintenance:</p> <ol style="list-style-type: none"> 1. All revisions to Fleet Garage plans constituted a revision to Fleet Maintenance plans. 2. Revision to building footprint prior to initial Development Order submittal. 3. Revision prior to Development Order issuance to add mechanical pad on north side of the building. 4. AFC Plan revision to revise sewer lateral location, oil separator and storm pipe layout.
<p>C. PHASE 1 – As-Built Survey Review / Revisions: (Item #2 on Exhibit B)</p> <ol style="list-style-type: none"> 1. Multiple reviews outside of scope. 2. Enhanced coordination effort to certify project in lieu of construction defects.
<p>D. PHASE 1 – Review, meetings and coordination regarding the incorrect installation of pond french drains (Item #3 on Exhibit B)</p>
<p>E. PHASE 1 – Administration Building parking lot asphalt compaction and installation concerns (Item #4 on Exhibit B)</p>
<p>F. PHASE 1 – Review, meetings and coordination regarding pond construction and maintenance (Item #5 on Exhibit B)</p>
<p>G. PHASE 1 – Miscellaneous meetings and other (Item #6 on Exhibit B)</p>

Attached to this proposal as **Exhibit B** is a breakdown of the time and cost associated with these task items.

These services were performed in support of construction coordination, contractor requests, owner requested changes, and regulatory coordination during the construction phase.

South Walton Mosquito Control District - Campus Upgrade Project – Phase II
Additional Services – Contract Administration
May 8, 2026
Page 3 of 3

Thank you for considering these additional scope items for this project. We look forward to continuing to assist with the successful completion of the project.

Sincerely,

O'CONNELL & ASSOCIATES
CONSULTING ENGINEERS, LLC

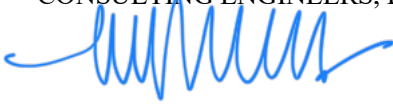
A handwritten signature in blue ink, appearing to read 'Neill R. O'Connell', with a stylized flourish at the end.

Neill R. O'Connell, P.E.
President

OConnell & Associates Consulting Engineers, LLC

TIME DETAILS

FILTERS USED :

Project In : 24111 | Additional Services-Civil | So Walton Mosquito Control-PH 2, 24111 | Contract Administration | So Walton Mosquito Control-PH 2
and Time Entry Date In : 12/1/2024 To 3/31/2026

PROJECT : 24111 | So Walton Mosquito Control-PH 2

DATE	EMPLOYEE	DESCRIPTION	ACTUAL HOURS	CLIENT HOURS	ENTRY AMOUNT *
12/3/2024	Alex London	Meetings <i>OAC meeting (attended onsite)</i>	2.50	2.50	\$300.00 A
12/10/2024	Alex London	Meetings <i>OAC Meeting (attended virtually)</i>	1.00	1.00	\$120.00 A
12/30/2024	Jonathan Nash	Civil Engineering <i>Coord. with Steven RE new building footprint</i>	0.50	0.50	\$100.00 A
1/3/2025	Alex London	Civil Engineering <i>started revisions to fleet garage (formatting new building xref, updated base file and imperv. area spreadsheet, and began re-grading)</i>	3.75	3.75	\$412.50 A
1/6/2025	Alex London	Civil Engineering <i>continuing grading revisions</i>	3.00	3.00	\$330.00 A
1/7/2025	Alex London	Meetings <i>OAC meeting (Phase 1) attended onsite (3.25hr) discussing landscape phasing with Jon (0.5hr)</i>	3.75	3.75	\$412.50 A
1/7/2025	Jonathan Nash	General Engineering <i>Landscape Sod Review with Alex</i>	0.50	0.50	\$100.00 A
1/7/2025	Alex London	Civil Engineering <i>updating maintenance building base files per fleet garage revisions, working on maintenance building storm layout, coordinating landscape revisions with Michael</i>	3.25	3.25	\$357.50 A
1/8/2025	Alex London	General Engineering <i>creating landscape phasing exhibit</i>	2.25	2.25	\$247.50 A
1/8/2025	Jonathan Nash	General Engineering <i>Sod issue with Alex</i>	0.75	0.75	\$150.00 A
1/8/2025	Ryan Scott	Civil Engineering <i>Updating lighting plan.</i>	0.50	0.50	\$70.00 A
1/8/2025	Michael Ekblad	Civil Engineering <i>Plan revision based on building changes</i>	1.00	1.00	\$200.00 A
1/8/2025	Ryan Scott	Civil Engineering <i>Updating landscape and irrigation plans.</i>	2.50	2.50	\$350.00 A
1/10/2025	Michael Ekblad	Civil Engineering <i>Plan update and submittal coordination</i>	1.00	1.00	\$200.00 A
1/10/2025	Michael Ekblad	Civil Engineering <i>Plan update & submittal coordination</i>	3.00	3.00	\$600.00 A
1/21/2025	Alex London	General Engineering <i>Phase 1 biweekly OAC meeting</i>	0.50	0.50	\$55.00 A
1/24/2025	Alex London	Field Work	1.00	1.00	\$110.00 A

GROUPED BY Root Project

*U=Un-Submitted, S=Submitted, A=Approved, F=Forwarded, R=Rejected, UA=Un-Approved

OConnell & Associates Consulting Engineers, LLC

TIME DETAILS

PROJECT : 24111 | So Walton Mosquito Control-PH 2

DATE	EMPLOYEE	DESCRIPTION	ACTUAL HOURS	CLIENT HOURS	ENTRY AMOUNT *
		<i>cleaning up CAD files for Phase 1 to send to Contractor. (Requested by gas company)</i>			
1/28/2025	Michael Ekblad	Civil Engineering	1.50	1.50	\$225.00 A
		<i>Attending OAC meeting and preparation</i>			
1/28/2025	Alex London	Civil Engineering	4.25	4.25	\$467.50 A
		<i>preparing for Phase 1 Landscape Coordination meeting (0.25hr) Phase 1 landscape coordination meeting (attended onsite, 3.25hr) Email coordination with WSI team (0.75hr)</i>			
1/31/2025	Michael Ekblad	Civil Engineering	0.50	0.50	\$75.00 A
		<i>Coordination with Arch for sign landscaping</i>			
2/4/2025	Michael Ekblad	Civil Engineering	2.50	2.50	\$375.00 A
		<i>Sign planting coordination with DAG</i>			
2/10/2025	Jonathan Nash	Civil Engineering	0.50	0.50	\$75.00 A
		<i>Curb/Guardrail Issue with Alex</i>			
2/10/2025	Neill O'Connell	Add Service Review	0.75	0.75	\$187.50 A
		<i>review new outdoor dining pavillion</i>			
2/10/2025	Jonathan Nash	Structural Engineering	0.50	0.50	\$60.00 A
		<i>Pavillion research</i>			
2/10/2025	Alex London	Civil Engineering	0.75	0.75	\$82.50 A
		<i>header curb detail for bridge roadway enhancements, discussing with Jon</i>			
2/11/2025	Alex London	Civil Engineering	3.00	3.00	\$330.00 A
		<i>Updating fleet garage plans per revisions, working toward 75% CD set for maintenance building to turnover to Arch. on Friday</i>			
2/14/2025	Jonathan Nash	Civil Engineering	0.50	0.50	\$75.00 A
		<i>Culvert crossing issue</i>			
2/17/2025	Jonathan Nash	Civil Engineering	0.25	0.25	\$50.00 A
		<i>Sign question with Michael</i>			
2/17/2025	Michael Ekblad	Civil Engineering	0.75	0.75	\$150.00 A
		<i>Sod layout review, sign coordination</i>			
2/18/2025	Alex London	Field Work	1.00	1.00	\$110.00 A
		<i>Bi-weekly OAC meeting for Admin. Building</i>			
2/18/2025	Neill O'Connell	additional service	0.50	0.50	\$125.00 A
2/19/2025	Jonathan Nash	Civil Engineering	0.50	0.50	\$100.00 A
		<i>Culvert Crossing RFI Internal Meeting</i>			
2/19/2025	Neill O'Connell	additional service	0.75	0.75	\$187.50 A
		<i>bridge ditch crossing</i>			
2/19/2025	Alex London	Civil Engineering	1.00	1.00	\$110.00 A
		<i>Internal meeting with Josh, Neill and Jon to review RFI 32 for culvert crossing responding to RFI 32</i>			
2/24/2025	Alex London	Meetings	0.75	0.75	\$82.50 A
		<i>landscape coordination meeting</i>			

GROUPED BY Root Project

*U=Un-Submitted, S=Submitted, A=Approved, F=Forwarded, R=Rejected, UA=Un-Approved

OConnell & Associates Consulting Engineers, LLC

TIME DETAILS

PROJECT : 24111 | So Walton Mosquito Control-PH 2

DATE	EMPLOYEE	DESCRIPTION	ACTUAL HOURS	CLIENT HOURS	ENTRY AMOUNT *
2/24/2025	Michael Ekblad	Civil Engineering <i>Sod layout coordination meeting</i>	1.00	1.00	\$200.00 A
3/4/2025	Alex London	Meetings <i>bi-weekly OAC (attended onsite)</i>	2.50	2.50	\$300.00 A
3/5/2025	Alex London	Civil Engineering <i>received latest and greatest arch. plans, footprint changed, began base file layout revisions</i>	2.50	2.50	\$275.00 A
3/6/2025	Alex London	Civil Engineering <i>continuing layout revisions and beginning grading revisions</i>	6.75	6.75	\$742.50 A
3/6/2025	Jonathan Nash	Civil Engineering <i>Building & Grading Revisions</i>	1.25	1.25	\$250.00 A
3/7/2025	Alex London	Civil Engineering <i>finished grading revisions and updating spot grade points</i>	6.75	6.75	\$742.50 A
3/7/2025	Jonathan Nash	Civil Engineering <i>Maintenance grading issues</i>	1.25	1.25	\$250.00 A
3/10/2025	Alex London	Civil Engineering <i>finishing grading revisions and new inlet locations</i>	2.00	2.00	\$220.00 A
3/12/2025	Michael Ekblad	Civil Engineering <i>Entry landscaping for sign</i>	2.50	2.50	\$500.00 A
3/13/2025	Michael Ekblad	Civil Engineering <i>Update per arch for entry planting</i>	1.25	1.25	\$250.00 A
3/17/2025	Jonathan Nash	Inspection Services <i>Coord. with County RE Pre-con</i>	0.25	0.25	\$50.00 A
3/18/2025	Jonathan Nash	Inspection Services <i>Pond Issue with Alex</i>	0.50	0.50	\$100.00 A
3/19/2025	Jonathan Nash	Inspection Services <i>CA - Pond Issue</i>	0.50	0.50	\$100.00 A
3/19/2025	Alex London	Meetings <i>discussing pond sediment issue with Brice and Jon, coordinating with contractor to schedule an onsite meeting to discuss corrective action (0.75hr) onsite meeting, reviewing geotech findings, discussing with Jon and sending email to contractor summarizing issue with proposed solution</i>	4.00	4.00	\$480.00 A
3/21/2025	Jonathan Nash	Inspection Services <i>Contractor requested culvert letter</i>	0.25	0.25	\$50.00 A
3/21/2025	Alex London	Inspection Services <i>contractor requested culvert letter, discussed with Jon and told contractor this should not be necessary</i>	0.50	0.50	\$60.00 A
3/24/2025	Jonathan Nash	Inspection Services <i>Coord. with Public Works RE Culvert Issue</i>	0.25	0.25	\$50.00 A
3/25/2025	Alex London	Inspection Services	1.50	1.50	\$180.00 A

GROUPED BY Root Project

*U=Un-Submitted, S=Submitted, A=Approved, F=Forwarded, R=Rejected, UA=Un-Approved

OConnell & Associates Consulting Engineers, LLC

TIME DETAILS

PROJECT : 24111 | So Walton Mosquito Control-PH 2

DATE	EMPLOYEE	DESCRIPTION	ACTUAL HOURS	CLIENT HOURS	ENTRY AMOUNT *
		<i>bi-weekly OAC meeting (attended virtually)</i>			
3/26/2025	Alex London	Inspection Services	3.00	3.00	\$360.00 A
		<i>coordination with WSI regarding installation of underdrain piping, subcontractor improperly installed piping, WSI notified. Separate phone calls with DAG and WSI to discuss</i>			
3/26/2025	Jonathan Nash	Inspection Services	0.50	0.50	\$100.00 A
		<i>French Drain Issue with Alex</i>			
3/27/2025	Alex London	Inspection Services	0.50	0.50	\$60.00 A
		<i>more discussions with DAG about problems</i>			
4/1/2025	Jonathan Nash	Meetings	2.75	2.75	\$550.00 A
		<i>OAC Meeting & Follow-up with Neill</i>			
4/1/2025	Alex London	Inspection Services	2.75	2.75	\$330.00 A
		<i>attended OAC onsite with Jon</i>			
4/4/2025	Jonathan Nash	Civil Engineering	0.25	0.25	\$50.00 A
		<i>Add Service - Sidewalk Revision with Alex</i>			
4/4/2025	Michael Ekblad	Civil Engineering	2.00	2.00	\$300.00 A
		<i>Entry Sign planting revisions Coordination with SWMCD</i>			
4/8/2025	Michael Ekblad	Civil Engineering	0.25	0.25	\$37.50 A
		<i>Coordination for landscape deviation</i>			
4/9/2025	Michael Ekblad	Civil Engineering	5.00	5.00	\$750.00 A
		<i>Meeting with Client to review landscape reduction Drafting buffer reduction talking points</i>			
4/15/2025	Alex London	Civil Engineering	1.00	1.00	\$120.00 A
		<i>bi-weekly OAC meeting (attended on Teams)</i>			
4/24/2025	Alex London	General Engineering	0.75	0.75	\$82.50 A
		<i>Preparing CAD file for parking garage for Fire Protection consultant as requested by Arch.</i>			
4/29/2025	Alex London	Detail Library	2.50	2.50	\$0.00 A
		<i>working on underdrain detail</i>			
4/29/2025	Alex London	Meetings	1.00	1.00	\$110.00 A
		<i>bi-weekly OAC meeting</i>			
4/30/2025	Alex London	Detail Library	1.50	1.50	\$0.00 A
		<i>finishing french drain details and sending to Arch.</i>			
5/12/2025	Alex London	General Engineering	1.00	1.00	\$120.00 A
		<i>reviewing stormwater design with Jon ahead of OAC meeting tomorrow</i>			
5/13/2025	Jonathan Nash	Meetings	2.00	2.00	\$400.00 A
		<i>CA - Onsite Meeting, Review RAIs and SMS for Meeting</i>			
5/13/2025	Alex London	General Engineering	3.00	3.00	\$360.00 A
		<i>OAC (attended onsite)</i>			
5/20/2025	Alex London	General Engineering	1.25	1.25	\$137.50 A

GROUPED BY Root Project

*U=Un-Submitted, S=Submitted, A=Approved, F=Forwarded, R=Rejected, UA=Un-Approved

OConnell & Associates Consulting Engineers, LLC

TIME DETAILS

PROJECT : 24111 | So Walton Mosquito Control-PH 2

DATE	EMPLOYEE	DESCRIPTION	ACTUAL HOURS	CLIENT HOURS	ENTRY AMOUNT *
		<i>Cleaning up base files for maintenance building and fleet garage. Sending to Arch & GC for distribution to Site contractor</i>			
5/20/2025	Alex London	Shop Drawing / Submittal Review	0.75	0.75	\$82.50 A
		<i>Storm structure submittal review and approval for structures associated with fleet garage, sending to Steven</i>			
5/21/2025	Jonathan Nash	General Engineering	0.75	0.75	\$150.00 A
		<i>Pond Issue with Alex</i>			
5/21/2025	Neill O'Connell	Document Review	1.00	1.00	\$250.00 A
		<i>correspond w/ team re: stormwaster ponds / geotech</i>			
5/21/2025	Alex London	General Engineering	1.25	1.25	\$137.50 A
		<i>drafting email to Team outlining recommendations for additional geotech and as-built survey to resolve pond issue</i>			
5/22/2025	Neill O'Connell	Document Review	0.50	0.50	\$125.00 A
5/27/2025	Alex London	Meetings	1.50	1.50	\$180.00 A
		<i>OAC (attended virtually)</i>			
5/27/2025	Jonathan Nash	Meetings	1.25	1.25	\$250.00 A
		<i>OAC Meeting</i>			
6/6/2025	Alex London	General Engineering	0.50	0.50	\$60.00 A
		<i>phone call with Steven</i>			
6/6/2025	Michael Ekblad	Civil Engineering	0.25	0.25	\$37.50 A
		<i>Tree size sub and irrigation submittal follow up</i>			
6/10/2025	Jonathan Nash	General Engineering	0.50	0.50	\$100.00 A
		<i>Water line issue with Alex</i>			
6/10/2025	Alex London	General Engineering	1.75	1.75	\$210.00 A
		<i>biweekly OAC meeting (1.5hr) discussing new water line to existing mechanics shop with Jon (0.25hr)</i>			
6/11/2025	Michael Ekblad	Consultation	3.00	3.00	\$600.00 A
		<i>Preparing AFC plans</i>			
6/18/2025	Jonathan Nash	General Engineering	0.25	0.25	\$50.00 A
		<i>Bridge Revisions with Alex</i>			
6/18/2025	Alex London	General Engineering	0.25	0.25	\$27.50 A
		<i>phone call with Steven discussing requested plan updates for revised sidewalk at admin building pedestrian bridge</i>			
6/20/2025	Jonathan Nash	General Engineering	0.50	0.50	\$100.00 A
		<i>CA - Bridge questions with Rob</i>			
6/23/2025	Michael Ekblad	General Engineering	1.00	1.00	\$200.00 A
		<i>Irrigation submittal review</i>			
6/24/2025	Michael Ekblad	General Engineering	0.25	0.25	\$50.00 A
		<i>Submittal coordination with arch.</i>			
6/26/2025	Alex London	General Engineering	0.50	0.50	\$55.00 A
		<i>discussing revision requests from Steven about Admin. Bldg. with Jon</i>			
6/26/2025	Jonathan Nash	General Engineering	0.25	0.25	\$50.00 A

GROUPED BY Root Project

*U=Un-Submitted, S=Submitted, A=Approved, F=Forwarded, R=Rejected, UA=Un-Approved

OConnell & Associates Consulting Engineers, LLC

TIME DETAILS

PROJECT : 24111 | So Walton Mosquito Control-PH 2

DATE	EMPLOYEE	DESCRIPTION	ACTUAL HOURS	CLIENT HOURS	ENTRY AMOUNT *
		<i>Rain chain issue with Alex</i>			
6/27/2025	Alex London	General Engineering	0.50	0.50	\$55.00 A
		<i>email to Steven listing requirements for as-built survey</i>			
6/27/2025	Jonathan Nash	General Engineering	0.25	0.25	\$50.00 A
		<i>Project status Review</i>			
6/30/2025	Alex London	General Engineering	3.00	3.00	\$330.00 A
		<i>working through roof plan revisions (addition of downspouts), coordinating with Arch. about drawing issues, discussing revisions with Jon</i>			
6/30/2025	Jonathan Nash	Document Review	0.50	0.50	\$100.00 A
		<i>Rain Chain and Bridge issue with Alex</i>			
7/1/2025	Alex London	General Engineering	3.75	3.75	\$412.50 A
		<i>downspout updates complete, waiting to receive elevations of new bridge before proceeding with sidewalk revision</i>			
		<i>proceeding with grading revisions on sidewalk, approving a rain chain detail for Steven to provide to WSI, updating plan sheets and adding revision clouds</i>			
7/1/2025	Jonathan Nash	Document Review	0.50	0.50	\$100.00 A
		<i>Rain chain issue</i>			
7/1/2025	Michael Ekblad	General Engineering	1.00	1.00	\$200.00 A
		<i>Submittal review</i>			
7/2/2025	Jonathan Nash	Document Review	0.50	0.50	\$100.00 A
		<i>Review and sign revised Phase 1 plan</i>			
7/2/2025	Michael Ekblad	General Engineering	1.00	1.00	\$200.00 A
		<i>landscape plan update based on generator</i>			
7/2/2025	Alex London	General Engineering	1.00	1.00	\$110.00 A
		<i>finalized plan updates, sent to Jon for review and sign, minor revision per Jon</i>			
7/3/2025	Michael Ekblad	General Engineering	1.50	1.50	\$300.00 A
		<i>Plan update for generator</i>			
7/8/2025	Alex London	General Engineering	1.75	1.75	\$192.50 A
		<i>Phase 1 OAC meeting (attended virtually)</i>			
7/9/2025	Michael Ekblad	General Engineering	0.25	0.25	\$50.00 A
		<i>AFC plan update</i>			
7/11/2025	Michael Ekblad	General Engineering	0.50	0.50	\$100.00 A
		<i>Plan update meeting with Allied professionals</i>			
7/11/2025	Alex London	General Engineering	0.50	0.50	\$55.00 A
		<i>discussing revisions with Michael</i>			
7/14/2025	Jonathan Nash	Inspection Services	0.25	0.25	\$50.00 A
		<i>Coord with Regional RE Fees</i>			
7/15/2025	Alex London	General Engineering	0.75	0.75	\$82.50 A
		<i>coordinating with Steven about removing dumpster pad, discussing impact fee waiver with Jon</i>			
7/15/2025	Jonathan Nash	Inspection Services	0.25	0.25	\$50.00 A

GROUPED BY Root Project

*U=Un-Submitted, S=Submitted, A=Approved, F=Forwarded, R=Rejected, UA=Un-Approved

OConnell & Associates Consulting Engineers, LLC

TIME DETAILS

PROJECT : 24111 | So Walton Mosquito Control-PH 2

DATE	EMPLOYEE	DESCRIPTION	ACTUAL HOURS	CLIENT HOURS	ENTRY AMOUNT *
		<i>Coord. with Regional RE Fee Waiver</i>			
7/16/2025	Alex London	General Engineering <i>updating maintenance building plans to reflect additional downspouts, coordination with Steven updating admin building plans for additional downspouts and size reduction on dumpster pad both plan sets printed and ready for digital</i>	7.50	7.50	\$825.00 A
7/17/2025	Jonathan Nash	Inspection Services <i>Review and sign revised plans, as-built review, asphalt issue</i>	1.50	1.50	\$300.00 A
7/17/2025	Alex London	General Engineering <i>phone call with Darrin discussing asphalt issues, as-built review, site visit to inspect asphalt</i>	7.50	7.50	\$825.00 A
7/18/2025	Alex London	General Engineering <i>finished as-built review notes and compiled into draft response to WSI</i>	6.00	6.00	\$660.00 A
7/18/2025	Michael Ekblad	General Engineering <i>update drawing for transformer</i>	1.00	1.00	\$200.00 A
7/18/2025	Jonathan Nash	Inspection Services <i>As-built review</i>	0.25	0.25	\$50.00 A
7/21/2025	Alex London	General Engineering <i>reviewing Regional Utilities requirements for as-built and testing, revising as-built review notes (1.5hr) drafting PW & WW completion forms (0.75hr)</i>	2.25	2.25	\$247.50 A
7/21/2025	Jonathan Nash	Inspection Services <i>Water/WW Closeout with Alex, call Randy</i>	0.25	0.25	\$50.00 A
7/22/2025	Alex London	General Engineering <i>onsite OAC and site walk, travel to and from</i>	2.75	2.75	\$302.50 A
7/23/2025	Ryan Scott	General Engineering <i>Reviewing as-builts.</i>	0.50	0.50	\$70.00 A
7/23/2025	Alex London	General Engineering <i>refining as-built review, reviewing with Ryan (1.25hr) Pre-construction meeting onsite, travel to and from (1.75hr) reviewing as-built with Jon again, revisions (1.50hr)</i>	4.50	4.50	\$495.00 A
7/23/2025	Jonathan Nash	Inspection Services <i>Asbuilt Review</i>	1.50	1.50	\$300.00 A
7/24/2025	Alex London	General Engineering <i>more review and revisions with Jon, finalized and distributed</i>	2.25	2.25	\$247.50 A
7/24/2025	Jonathan Nash	Inspection Services <i>As-built review with Alex</i>	0.25	0.25	\$50.00 A
7/28/2025	Jonathan Nash	General Engineering <i>Coord.</i>	0.25	0.25	\$50.00 A
8/1/2025	Alex London	Shop Drawing / Submittal Review <i>submittal review for maintenance building storm structures and undergrounder utilities for both garage and maintenance building</i>	3.25	3.25	\$357.50 A
8/7/2025	Alex London	Shop Drawing / Submittal Review	2.75	2.75	\$302.50 A

GROUPED BY Root Project

*U=Un-Submitted, S=Submitted, A=Approved, F=Forwarded, R=Rejected, UA=Un-Approved

OConnell & Associates Consulting Engineers, LLC

TIME DETAILS

PROJECT : 24111 | So Walton Mosquito Control-PH 2

DATE	EMPLOYEE	DESCRIPTION	ACTUAL HOURS	CLIENT HOURS	ENTRY AMOUNT *
		<i>submittal coordination with Steven, finalizing underground utility submittal review, sending to Steven (2.25hr) phone call with contractor answering questions about submittal (0.5hr)</i>			
8/8/2025	Jonathan Nash	Meetings	0.50	0.50	\$100.00 A
		<i>As-built review meeting with Contractor</i>			
8/8/2025	Alex London	Shop Drawing / Submittal Review	0.50	0.50	\$55.00 A
		<i>meeting with contractor to discuss certification and as-built comments</i>			
8/12/2025	Alex London	Meetings	1.00	1.00	\$110.00 A
		<i>OAC Meeting</i>			
8/22/2025	Alex London	General Engineering	1.50	1.50	\$165.00 A
		<i>cleaning up CAD base files and sending to contractor per request</i>			
8/26/2025	Alex London	General Engineering	1.25	1.25	\$137.50 A
		<i>biweekly OAC meeting (attended online)</i>			
8/29/2025	Alex London	General Engineering	2.00	2.00	\$220.00 A
		<i>reviewing underground utility resubmittal</i>			
9/2/2025	Alex London	General Engineering	2.50	2.50	\$275.00 A
		<i>finishing underground utilities resubmittal review (1hr) email coordination with Randy Taylor regarding water closeout (0.50hr) email coordination with contractor regarding as-builts (1hr)</i>			
9/2/2025	Jonathan Nash	Inspection Services	0.50	0.50	\$100.00 A
		<i>Utility As-built with Alex</i>			
9/3/2025	Jonathan Nash	Inspection Services	0.50	0.50	\$100.00 A
		<i>As-built issue with Alex</i>			
9/3/2025	Alex London	General Engineering	2.00	2.00	\$220.00 A
		<i>as-built coordination (1.5hr) reviewing underground utilities resubmittal #2 (0.50hr)</i>			
9/4/2025	Jonathan Nash	Inspection Services	0.75	0.75	\$150.00 A
		<i>Admin Building Closeout Issue, Coord. with County</i>			
9/4/2025	Alex London	General Engineering	1.00	1.00	\$110.00 A
		<i>more contractor coordination regarding as-builts</i>			
9/5/2025	Jonathan Nash	Inspection Services	0.25	0.25	\$50.00 A
		<i>Revised Roof drains review with Alex</i>			
9/5/2025	Alex London	General Engineering	1.00	1.00	\$110.00 A
		<i>Coordination with Arch. regarding new sidewalk drains</i>			
9/8/2025	Ansley Williams	General Engineering	0.50	0.50	\$65.00 A
		<i>FDEP PWS & WW Cert form discussion w AL for RU</i>			
9/8/2025	Alex London	General Engineering	3.50	3.50	\$385.00 A
		<i>Reviewing updated as-built for parking lot to check ADA compliance, coordinating with Ansley to start drafting partial certification letter. Continuing coordination with Arch regarding additional drains on north sidewalk, detail provided to Arch for approval. Discussion with Jon and Arch about downspout pipe capacity issues.</i>			

GROUPED BY Root Project

*U=Un-Submitted, S=Submitted, A=Approved, F=Forwarded, R=Rejected, UA=Un-Approved

OConnell & Associates Consulting Engineers, LLC

TIME DETAILS

PROJECT : 24111 | So Walton Mosquito Control-PH 2

DATE	EMPLOYEE	DESCRIPTION	ACTUAL HOURS	CLIENT HOURS	ENTRY AMOUNT *
9/9/2025	Alex London	General Engineering <i>working on draft certification letter for phase 1</i>	1.00	1.00	\$110.00 A
9/9/2025	Michael Ekblad	Site Visit / Inspection <i>Site visit for phase 1 landscape/irrigation</i>	3.00	3.00	\$600.00 A
9/10/2025	Michael Ekblad	Site Visit / Inspection <i>Preparing observation report</i>	2.50	2.50	\$500.00 A
9/10/2025	Alex London	General Engineering <i>marking up as-built survey of parking lot grades (need more assurances/survey updates), redoing roof drainage and pipe capacity calculations for downspout rerouting proposed by contractor, coordination with contractor and Arch. regarding a solution, discussing light pole/FH conflict with Jon, drafting water and sewer completion forms for Regional and FDEP closeout</i>	8.00	8.00	\$880.00 A
9/11/2025	Alex London	General Engineering <i>Finalizing parking lot as-built submittal review, coordinating with Jon Coordination with Steven regarding light pole conflict</i>	3.00	3.00	\$330.00 A
9/11/2025	Jonathan Nash	General Engineering <i>ADA Issue</i>	0.25	0.25	\$50.00 A
9/12/2025	Thomas Brannon	Document Review	0.75	0.75	\$90.00 A
9/12/2025	Ansley Williams	General Engineering <i>FDEP PWS & WW Cert form discussion w AL for RU</i>	0.25	0.25	\$32.50 A
9/12/2025	Alex London	General Engineering <i>water and sewer as-built review, checking lift station deviations with Thomas, returned approved as noted, waiting on S&S to begin certification process</i>	3.50	3.50	\$385.00 A
9/12/2025	Michael Ekblad	Site Visit / Inspection <i>Irrigation review</i>	0.25	0.25	\$50.00 A
9/15/2025	Alex London	General Engineering <i>RFI coordination with Arch, discussing resolution for light pole conflict. Requesting signatures for water and sewer completion forms</i>	1.50	1.50	\$165.00 A
9/16/2025	Jonathan Nash	Inspection Services <i>ADA Issue with Alex, Phase 1 Cert</i>	1.50	1.50	\$300.00 A
9/16/2025	Alex London	General Engineering <i>ADA as-built final review, cert letter finalization with Jon</i>	2.00	2.00	\$220.00 A
9/17/2025	Jonathan Nash	Inspection Services <i>Review and sign utility cert package</i>	0.75	0.75	\$150.00 A
9/17/2025	Alex London	General Engineering <i>received all required signatures, assembled final submittal package, submitted via email to Randy Taylor</i>	1.50	1.50	\$165.00 A
9/23/2025	Alex London	General Engineering <i>OAC meeting and site walk, travel to and from (3.5hr) NOVA pond perc test report review with Jon (0.5hr) revisiting inline drain and grate options for sidewalk fill in and downspout connection, phone call with Steven (0.5hr)</i>	4.50	4.50	\$495.00 A
9/23/2025	Michael Ekblad	Site Visit / Inspection <i>Drainage coordination w/ Arch</i>	0.25	0.25	\$50.00 A

GROUPED BY Root Project

*U=Un-Submitted, S=Submitted, A=Approved, F=Forwarded, R=Rejected, UA=Un-Approved

OConnell & Associates Consulting Engineers, LLC

TIME DETAILS

PROJECT : 24111 | So Walton Mosquito Control-PH 2

DATE	EMPLOYEE	DESCRIPTION	ACTUAL HOURS	CLIENT HOURS	ENTRY AMOUNT *
9/23/2025	Jonathan Nash	General Engineering <i>Pond Issue with Alex</i>	0.50	0.50	\$100.00 A
9/25/2025	Michael Ekblad	Site Visit / Inspection <i>Follow up on landscape observations</i>	0.25	0.25	\$50.00 A
9/25/2025	Alex London	General Engineering <i>phone call with Arch. discussing sidewalk area drains, drafting email with recommendation</i>	0.75	0.75	\$82.50 A
9/26/2025	Ansley Williams	General Engineering <i>Review FDEP forms from RU</i>	0.50	0.50	\$65.00 A
9/30/2025	Ansley Williams	General Engineering <i>Receive signed FDEP PWS & WW Forms from RU & Submit PWS & WW Applications and associated documents to FDEP, Coordinate w RU & FDEP to address FDEP PWS comment requesting locations of BacT tests on project map, Obtain FDEP WW Approval</i>	2.25	2.25	\$292.50 A
10/1/2025	Alex London	General Engineering <i>received asphalt core sample results, reviewing and comparing results against submittal and FDOT standards</i>	0.50	0.50	\$55.00 A
10/2/2025	Alex London	General Engineering <i>finishing review of asphalt density report and notifying Contractor of failure, discussing SMS issues with Thomas, RFI discussion via phone with Arch., email coordination with contractor regarding asphalt results</i>	3.25	3.25	\$357.50 A
10/2/2025	Jonathan Nash	Document Review <i>Review RFIs with Alex</i>	0.25	0.25	\$50.00 A
10/6/2025	Ansley Williams	Document Review <i>FDEP PWS Clearance confirmation, save approval from Oculus on server</i>	0.25	0.25	\$32.50 A
10/7/2025	Michael Ekblad	Meetings <i>Review BV responses to Landscape Inspection</i>	0.25	0.25	\$50.00 A
10/8/2025	Jonathan Nash	Document Review <i>RFIs with Alex</i>	0.50	0.50	\$100.00 A
10/8/2025	Alex London	General Engineering <i>phone call with Arch to discuss RFIs for Phase 1 & Phase 2, drafting responses to Phase 1 RFIs 43, 44, & 45, and Phase 2 RFI 25, reviewing with Jon, response revisions per Jon</i>	5.25	5.25	\$577.50 A
10/9/2025	Alex London	General Engineering <i>RFI response discussion with Jon</i>	2.25	2.25	\$247.50 A
10/10/2025	Jonathan Nash	Document Review <i>RFI Responses</i>	0.50	0.50	\$100.00 A
10/10/2025	Alex London	General Engineering <i>RFI response revisions per JN review</i>	0.50	0.50	\$55.00 A
10/13/2025	Alex London	Civil Engineering <i>phone call and email coordination with Darrin about water line RFI</i>	0.75	0.75	\$82.50 A
10/15/2025	Alex London	Civil Engineering	3.00	3.00	\$330.00 A

GROUPED BY Root Project

*U=Un-Submitted, S=Submitted, A=Approved, F=Forwarded, R=Rejected, UA=Un-Approved

OConnell & Associates Consulting Engineers, LLC

TIME DETAILS

PROJECT : 24111 | So Walton Mosquito Control-PH 2

DATE	EMPLOYEE	DESCRIPTION	ACTUAL HOURS	CLIENT HOURS	ENTRY AMOUNT *
		<i>Call from contractor to discuss existing waterline size after excavation, beginning to sketch new waterline extension to mechanics shop (0.25hr) AFC Rev5 revisions (2.75hr)</i>			
10/15/2025	Jonathan Nash	Civil Engineering	0.50	0.50	\$100.00 A
		<i>New Water service issue, Compact space issue</i>			
10/16/2025	Alex London	Civil Engineering	8.00	8.00	\$880.00 A
		<i>phone calls and coordination regarding upcoming fleet maintenance revisions (1.25 hr) Phase 1 revisions (AFC REV5) preliminarily complete pending JN review (6.75 hr)</i>			
10/17/2025	Michael Ekblad	Site Visit / Inspection	2.50	2.50	\$500.00 A
		<i>Site visit and follow up with Arch Lighting base submittal review</i>			
10/17/2025	Jonathan Nash	Civil Engineering	0.50	0.50	\$100.00 A
		<i>Utility Modifications</i>			
10/17/2025	Alex London	Civil Engineering	3.25	3.25	\$357.50 A
		<i>phone call from Darrin to discuss issues (0.50hr) review and revisions to AFC REV5 set per JN (2.75hr)</i>			
10/20/2025	Michael Ekblad	Site Visit / Inspection	0.50	0.50	\$100.00 A
		<i>Inspection follow up</i>			
10/27/2025	Alex London	Civil Engineering	1.50	1.50	\$165.00 A
		<i>drafting response to additional Pond testing results, reviewing with TB</i>			
10/28/2025	Michael Ekblad	Document Review	0.50	0.50	\$100.00 A
		<i>Light submittal review</i>			
10/28/2025	Alex London	Civil Engineering	2.75	2.75	\$302.50 A
		<i>OAC meeting (attended onsite)</i>			
10/30/2025	Alex London	Civil Engineering	0.25	0.25	\$27.50 A
		<i>discussing pond/french drain issues with Jon</i>			
11/5/2025	Alex London	Civil Engineering	0.75	0.75	\$82.50 A
		<i>asked by Arch to fill out our portion of revision narrative, drafted civil and landscape revision narrative</i>			
11/10/2025	Jonathan Nash	Civil Engineering	0.50	0.50	\$100.00 A
		<i>Add Service - Call with 850 RE Asphalt Issue</i>			
11/10/2025	Alex London	Civil Engineering	0.75	0.75	\$82.50 A
		<i>Arch coordination regarding downspout revision, revision not happening</i>			
11/11/2025	Thomas Brannon	Report Review	1.50	1.50	\$180.00 A
		<i>asphalt density research</i>			
11/11/2025	Alex London	Civil Engineering	2.00	2.00	\$220.00 A
		<i>researching and discussing asphalt density requirements with Jon & Thomas</i>			
11/12/2025	Michael Ekblad	Meetings	1.00	1.00	\$200.00 A
		<i>OAC meeting</i>			
11/12/2025	Alex London	Civil Engineering	1.25	1.25	\$137.50 A
		<i>RFI 51 received, requested additional info to respond appropriately (0.75hr) phone call with Darrin (0.50hr)</i>			

GROUPED BY Root Project

*U=Un-Submitted, S=Submitted, A=Approved, F=Forwarded, R=Rejected, UA=Un-Approved

OConnell & Associates Consulting Engineers, LLC

TIME DETAILS

PROJECT : 24111 | So Walton Mosquito Control-PH 2

DATE	EMPLOYEE	DESCRIPTION	ACTUAL HOURS	CLIENT HOURS	ENTRY AMOUNT *
11/13/2025	Alex London	Civil Engineering <i>reviewing corrected asphalt density test results</i>	0.50	0.50	\$55.00 A
11/17/2025	Michael Ekblad	Meetings <i>Punchlist coordination with Arch</i>	0.25	0.25	\$50.00 A
11/18/2025	Neill O'Connell	Meetings <i>review asphalt code</i>	0.50	0.50	\$125.00 A
11/19/2025	Neill O'Connell	Meetings <i>meet w/ JN re: asphalt spec. review FDOT Code</i>	0.75	0.75	\$187.50 A
11/19/2025	Alex London	Civil Engineering <i>called to inspect french drains at pond 1 prior to backfill, used wrong pipe per provided detail, contractor began removing pipe, travel to and from inspection (2.50 hr) preparing paper trail for Jon and Neill regarding asphalt issue (1 hr)</i>	3.50	3.50	\$385.00 A
11/20/2025	Michael Ekblad	Site Visit / Inspection <i>Landscape repunch coordination with Arch and contractor</i>	3.00	3.00	\$600.00 A
11/20/2025	Alex London	Civil Engineering <i>final punch walk inspection with Michael, travel to and from</i>	2.50	2.50	\$275.00 A
12/17/2025	Michael Ekblad	Document Review <i>Review lighting submittals</i>	1.50	1.50	\$300.00 A
1/13/2026	Ansley Williams	General Engineering <i>Look up all permit info and coord w NFWFMD to verify only one final as-built certification is needed to close out</i>	0.75	0.75	\$75.00 A
1/15/2026	Neill O'Connell	Document Review <i>review permit schedule w/ AL</i>	0.50	0.50	\$125.00 A
1/21/2026	Jonathan Nash	Civil Engineering <i>Add Service - CO Research with Alex</i>	0.25	0.25	\$50.00 A
1/21/2026	Alex London	Civil Engineering <i>discussing CO research with Jon, discussing contractors request to change asphalt spec</i>	1.25	1.25	\$137.50 A
1/21/2026	Jonathan Nash	Civil Engineering <i>Add Service - Asphalt Spec RAI from Warton Smith</i>	0.25	0.25	\$50.00 A
1/22/2026	Alex London	Civil Engineering <i>CO research and estimation</i>	5.00	5.00	\$550.00 A
1/23/2026	Alex London	Civil Engineering <i>researching FDOT spec 334, writing email response to WSI regarding asphalt density requirement, phone call with Darrin (2.25hr) CO research (2.75hr)</i>	5.00	5.00	\$550.00 A
1/23/2026	Jonathan Nash	Civil Engineering <i>Add Service - Response to RAI RE Asphalt Density Requirement</i>	0.50	0.50	\$100.00 A
1/28/2026	Neill O'Connell	add'l service scope review mtg	0.75	0.75	\$187.50 A

GROUPED BY Root Project

*U=Un-Submitted, S=Submitted, A=Approved, F=Forwarded, R=Rejected, UA=Un-Approved

OConnell & Associates Consulting Engineers, LLC

TIME DETAILS

PROJECT : 24111 | So Walton Mosquito Control-PH 2

DATE	EMPLOYEE	DESCRIPTION	ACTUAL HOURS	CLIENT HOURS	ENTRY AMOUNT *
1/28/2026	Alex London	Civil Engineering <i>Change order review meeting with JN and NOC</i>	0.50	0.50	\$55.00 A
1/28/2026	Jonathan Nash	Civil Engineering <i>CO Review with Neill and Alex</i>	0.50	0.50	\$100.00 A
2/3/2026	Alex London	Document Review <i>reviewing and responding to RFI 66 (concrete pavement clarification)</i>	1.25	1.25	\$137.50 A
2/10/2026	Alex London	General Engineering <i>received Mech. Pad detail from Josh, finalizing RFI 66 response and sending to DAG</i>	0.25	0.25	\$27.50 A
2/13/2026	Alex London	Site Visit / Inspection <i>rebar inspection for parking garage east driveway apron via photos from contractor, coordination with Tyson</i>	0.25	0.25	\$27.50 A
2/17/2026	Michael Ekblad	General Engineering <i>lighting review</i>	0.25	0.25	\$50.00 A
2/17/2026	Jonathan Nash	Civil Engineering <i>Client Meeting with W&S to discuss pond recovery, etc.</i>	0.75	0.75	\$150.00 A
2/17/2026	Alex London	Civil Engineering <i>meeting to discuss phase 1 remediation work, producing a map of spots to check elevations for in pond and sending to Darrin (1hr) phone call with Darrin</i>	2.00	2.00	\$220.00 A
2/18/2026	Michael Ekblad	General Engineering <i>Irrigation submittal review</i>	1.50	1.50	\$300.00 A
2/23/2026	Alex London	Civil Engineering <i>relaying as-built requirements to contractor for Fleet Garage</i>	0.25	0.25	\$27.50 A
3/5/2026	Alex London	Site Visit / Inspection <i>final punch-list walk for fleet garage, travel to and from (2.75hr) uploading photos</i>	3.25	3.25	\$357.50 A
3/18/2026	Dillon Daggett	Site Visit / Inspection <i>On-site visit for landscape inspection.</i>	3.00	3.00	\$330.00 A
3/18/2026	Alex London	Shop Drawing / Submittal Review <i>received as-built submittal for fleet garage, reviewing and marking up</i>	0.50	0.50	\$55.00 A
3/18/2026	Michael Ekblad	Inspection Services <i>Site visit for landscape inspection</i>	3.25	3.25	\$650.00 A
3/18/2026	Michael Ekblad	Civil Engineering <i>Site lighting update per client request</i>	1.25	1.25	\$250.00 A
3/19/2026	Alex London	Shop Drawing / Submittal Review <i>continuing mark-ups, reviewing with JN, revising per JN</i>	1.50	1.50	\$165.00 A
3/19/2026	Michael Ekblad	Inspection Services <i>Inspection report and site walk with Client</i>	3.25	3.25	\$650.00 A
3/20/2026	Alex London	Shop Drawing / Submittal Review <i>updating as-built review</i>	0.25	0.25	\$27.50 A

GROUPED BY Root Project

*U=Un-Submitted, S=Submitted, A=Approved, F=Forwarded, R=Rejected, UA=Un-Approved

OConnell & Associates Consulting Engineers, LLC

TIME DETAILS

PROJECT : 24111 | So Walton Mosquito Control-PH 2

DATE	EMPLOYEE	DESCRIPTION	ACTUAL HOURS	CLIENT HOURS	ENTRY AMOUNT *
3/20/2026	Michael Ekblad	Inspection Services <i>Coordination with Architect for landscape observations and fleet garage</i>	0.25	0.25	\$50.00 A
3/20/2026	Alex London	Civil Engineering <i>writing remediation work memo</i>	2.00	2.00	\$220.00 A
3/24/2026	Michael Ekblad	Inspection Services <i>Coordination with Contractor for landscape issues</i>	0.25	0.25	\$50.00 A
3/24/2026	Alex London	Shop Drawing / Submittal Review <i>Fleet garage as-built update (0.25hr) Darrin phone call (0.5hr)</i>	0.75	0.75	\$82.50 A
3/24/2026	Alex London	Civil Engineering <i>18178 Pond memo update</i>	0.25	0.25	\$27.50 A
3/30/2026	Alex London	Shop Drawing / Submittal Review <i>revising as-built review per JN comments, sent to DAG for distribution</i>	1.00	1.00	\$110.00 A
3/30/2026	Jonathan Nash	Inspection Services <i>Internal Landscape inspection review with Michael</i>	0.25	0.25	\$50.00 A
3/31/2026	Alex London	Shop Drawing / Submittal Review <i>contractor email questioning as-built comments, phone call with Steven to discuss, responding</i>	1.00	1.00	\$110.00 A
24111 SO WALTON MOSQUITO CONTROL-PH 2 Total:			355.00	355.00	\$47,505.00
GRAND TOTAL:			355.00	355.00	\$47,505.00

GROUPED BY Root Project

*U=Un-Submitted, S=Submitted, A=Approved, F=Forwarded, R=Rejected, UA=Un-Approved

EXHIBIT B

ALL REPORTS, PLANS, SPECIFICATIONS, COMPUTERS FILES, FIELD DATA, NOTES AND OTHER DOCUMENTS AND INSTRUMENTS OF SERVICE SHALL REMAIN THE PROPERTY OF THE CONSULTANT. THE CONSULTANT SHALL RETAIN ALL COMMON LAW, STATUTORY AND OTHER RESERVED RIGHTS, INCLUDING THE COPYRIGHT THEREIN. PURSUANT TO FLORIDA STATUTES, SECTION 558.0935, AN INDIVIDUAL EMPLOYEE OR AGENT MAY NOT BE HELD INDIVIDUALLY LIABLE FOR NEGLIGENCE.

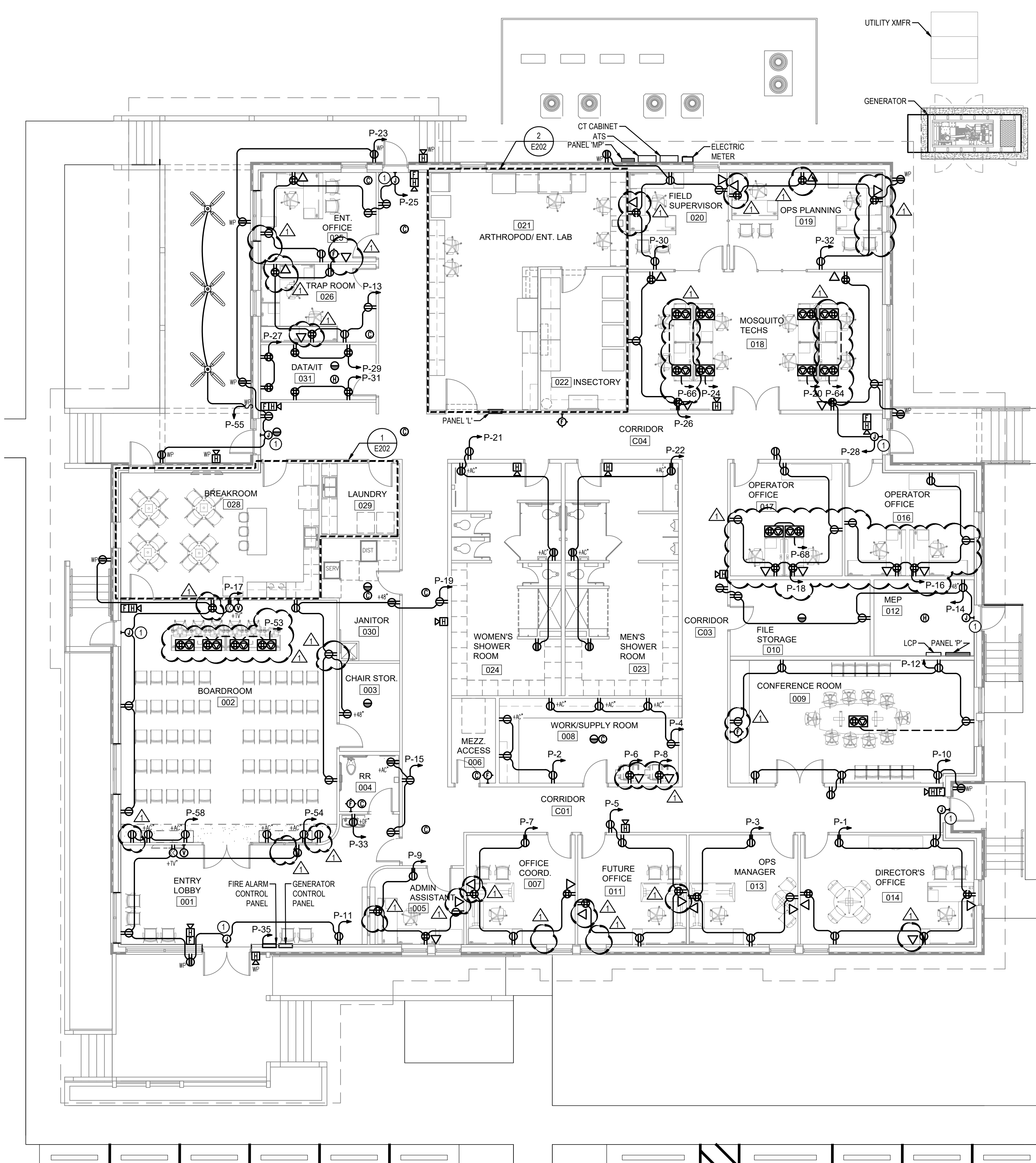

KEYNOTES

① PROVIDE POWER AT DOORS, TO BE TERMINATED BY OTHERS



ARCHITECTS
 DAG Architects, AAC000745
 1223 Airport Road Destin, Florida 32541
 850.837.8152 www.dagarchitects.com

100% CONSTRUCTION DOCUMENTS

South Walton County Mosquito Control District
 New Headquarters Building

774 North County Highway 393
 Santa Rosa Beach, Florida 32459

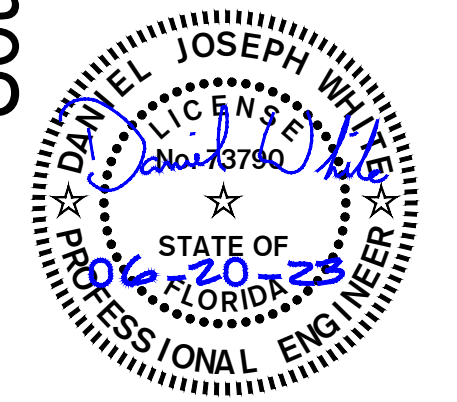

No.	Description	Date
△ ASI #002		06.12.24

FLOOR PLAN - POWER
 1/8" = 1'-0"
 0 4 8 16

HG Engineers
 142 E. Edin Parkway SE
 Fort Walton Beach, Florida, 32548
 E-mail: office@hgeengineers.com
 Ph: 850.243.6723
 FL Authorization No. 00006680
 Christopher A. Gaskin, FL PE No. 53924
 Thomas A. Alexander, FL PE No. 73172
 Daniel J. White, FL PE No. 73790
 Caleb W. Leonard, FL PE No. 91782

2043 Job No.

FLOOR PLAN - POWER

Project number: 18106
 Date: 10-04-2023
 PIC: CP
 PM: RE

E201

SYSTEM		208/120V 3Φ 4W							
RATING		600A M.L.O. 42,000 AIC MINIMUM							
ENCLOSURE		NEMA3R SURFACE MOUNT							
OPTIONS BOLT ON BREAKERS									
CKT #	SERVING	CKT BKR		CONNECTED LOAD (VA)		CKT BKR		SERVING	CKT #
		TRIP	POLE	POLE	TRIP	POLE	TRIP		
1	HP-1	50	3	5521	2282	3	20	HP-2	2
3	---	-	-	-	-	-	-	---	4
5	HP-3	40	3	4056	4056	3	20	HP-4	6
7	---	-	-	-	-	-	-	---	8
9	MHP-1	30	2	1872	1872	2	40	MHP-2	10
11	---	-	-	-	-	-	-	---	12
13	MHP-3	30	2	1456	3744	2	40	MHP-4	14
15	---	-	-	-	-	-	-	---	16
17	AHU-1	60	2	8614	3774	2	25	AHU-2	18
19	---	-	-	-	-	-	-	---	20
21	AHU-3	50	2	7174	7174	2	50	AHU-4	22
23	---	-	-	-	-	-	-	---	24
25	BATTERY CHARGER	20	1	1000	-	1	-	SPACE ONLY	26
27	BLOCKHEATER	20	2	2500	2496	2	30	LIFT STATION	28
29	---	-	-	-	-	-	-	---	30
31	PANEL P	225	3	63519	17630	3	125	PANEL L	32
33	---	-	-	-	-	-	-	---	34
35	---	-	-	-	-	-	-	---	36
37	OACU-1	80	3	18770	0	3	30	SURGE PROTECTIVE DEVICE	38
39	---	-	-	-	-	-	-	---	40
41	---	-	-	-	-	-	-	---	42
TOTAL CONNECTED LOAD =				157510 VA / 360				= 437.5 A	

POWER PANEL

SYSTEM		208/120V 3Φ 4W							
RATING		125A M.L.O. 10,000 AIC MINIMUM							
ENCLOSURE		NEMA 1 RECESSED MOUNT							
OPTIONS BOLT ON BREAKERS									
CKT #	SERVING	CKT BKR		CONNECTED LOAD (VA)		CKT BKR		SERVING	CKT #
		TRIP	POLE	POLE	TRIP	POLE	TRIP		
1	LTG - LAB LIGHTING	20	1	300	720	1	20	SUBZERO FREEZER	2
3	INCUBATOR	20	1	1236	600	1	15	FREEZER	4
5	INCUBATOR	20	1	1236	600	1	15	REFRIG.	6
7	INCUBATOR	20	1	1236	900	1	20	REC - CONVENIENCE	8
9	INCUBATOR	20	1	1236	360	1	20	REC - DESK	10
11	REC - ARBO STATION	20	1	180	180	1	20	REC - CENTRIFUGE	12
13	REC - DESK	20	1	360	360	1	20	REC - DESK	14
15	REC - DESK	20	1	360	360	1	20	REC - DESK	16
17	REC - PCR	20	1	180	360	1	20	REC - DESK	18
19	REC - DESK	20	1	180	180	1	20	REC - DESK	20
21	REC - DESK	20	1	360	180	1	20	REC - DESK	22
23	REC - GARBAGE DISPOSAL	20	1	1000	1000	1	20	DISHWASHER	24
25	BIO SAFETY CABINET	20	1	744	1000	1	20	CHEMHOOD	26
27	REC - ROOF	20	1	180	-	1	20	SPARE	28
29	SPARE	20	1	-	-	1	20	SPARE	30
31	SPARE	20	1	-	-	1	20	SPARE	32
33	SPARE	20	1	-	-	1	20	SPARE	34
35	SPARE	20	1	-	-	1	20	SPARE	36
37	SPARE	20	1	-	-	1	20	SPARE	38
39	SPACE ONLY	-	1	-	-	1	-	SPACE ONLY	40
41	SPACE ONLY	-	1	-	-	1	-	SPACE ONLY	42
43	SPACE ONLY	-	1	-	-	1	-	SPACE ONLY	44
45	SPACE ONLY	-	1	-	-	1	-	SPACE ONLY	46
47	SPACE ONLY	-	1	-	-	1	-	SPACE ONLY	48
49	AIR CURTAINS FF-1,2'	20	3	1296	-	1	-	SPACE ONLY	50
51	---	-	-	-	-	1	-	SPACE ONLY	52
53	---	-	-	-	-	1	-	SPACE ONLY	54
55	EXHAUST FAN	15	3	746	0	3	30	SURGE PROTECTIVE DEVICE	56
57	---	-	-	-	-	-	-	---	58
59	---	-	-	-	-	-	-	---	60
TOTAL CONNECTED LOAD =				17630 VA / 360				= 49.0 A	

SYSTEM		208/120V 3Φ 4W																				
RATING		225A M.L.O. 22,000 AIC MINIMUM																				
ENCLOSURE		NEMA1 SURFACE MOUNT																				
OPTIONS BOLT ON BREAKERS																						
EQUIPMENT DESIGNATION	DESCRIPTION	CFM	VOLT	Ø	ELECTRICAL LOAD							PROTECTION			CONDUCTOR / CONDUIT SIZE					DISC.	REMARKS	
					QTY	LARGEST	SUM OF REMAINING	ELECTRIC HEAT KW	OTHER VA	TOTAL CONNECTED VA	MCA	MOPP	TRIP	POLE	SETS	QTY.	SIZE	GND	CONDUIT			
BF-1,2	BOOSTER FAN	188	120	1	1	0.54					65	0.7	20	20	1	1	2	#12	#12	3/4"	GF5-20R	TIE TO RECEPTACLE CIRCUIT
CP-1	CIRCULATION PUMP		120	1	1	0.54					65	0.7	20	20	1	1	2	#12	#12	3/4"	GF5-20R	TIE TO RECEPTACLE CIRCUIT
EF-1	EXHAUST FAN	3472	208	3	1	2.07					746	2.6	15	15	3	1	3	#12	#12	3/4"	30/3R	
EF-2	EXHAUST FAN	630	208	1	1	0.28					58	0.4	15	15	2	1	3	#12	#12	3/4"	SWTCH	
EWC-1	ELECTRIC WATER COOLER		120	1							1000	8.3	20	20	1	1	2	#12	#12	3/4"	GF5-20R	PROVIDE GFICI OUTLET
GW-1	GAS WATER HEATER		120	1							0.5	20	20	1	1	3	#12	#12	3/4"	MOTORSMTCH		
FF-1	AIR CURTAIN	1379	208	3	1	1.8					648	2.3	15	15	3	1	3	#12	#12	3/4"	MOTORSMTCH	
FF-2	AIR CURTAIN	1442	208	3	1	1.8					648	2.3	15	15	3	1	3	#12	#12	3/4"	MOTORSMTCH	
AHU-1	AIR HANDLING UNIT	2000	208	1	1	6.8			7.2		8614	52	60	60	2	1	3	#8	#10	3/4"	60/2/1	
HP-1	HEAT PUMP	2000	208	1	2	23.7	2.8				5512	32	50	50	2	1	3	#8	#10	3/4"	BREAKER	
AHU-2	AIR HANDLING UNIT	870	208	1	1	4.3			2.88		3774	23	25	25	2	1	3	#10	#10	3/4"	30/2/1	
HP-2	HEAT PUMP	870	208	1	2	10.2	0.77				2282	15	20	20	2	1	3	#12	#12	3/4"	BREAKER	
AHU-3	AIR HANDLING UNIT	1200	208	1	1	6.8			5.76		7174	43	45	45	2	1	3	#8	#10	3/4"	60/2/1	
HP-3	HEAT PUMP	1200	208	1	2	16.7	2.8				4056	24	40	40	2	1	3	#8	#10	3/4"	BREAKER	
AHU-4	AIR HANDLING UNIT	1200	208	1	1	6.8			5.76		7174	43	45	45	2	1	3	#8	#10	3/4"	60/2/1	
HP-4	HEAT PUMP	1200	208	1	2	16.7	2.8				4056	24	40	40	2	1	3	#8	#10	3/4"	BREAKER	
MHP-1,2	MINISPLIT OUTDOOR UNIT	1940	208	1	1	9					1872	17	27	25	2	1	3	#10	#10	3/4"	BREAKER	
WM-1,1.2,1	MINISPLIT INDOOR UNIT										0										MOTORSMTCH	POWERED VIA OUTDOOR UNIT
MHP-3	MINISPLIT OUTDOOR UNIT	1590	208	1	1	7					1456	11	28	15	2	1	3	#12	#12	3/4"	BREAKER	
WM-3,1	MINISPLIT INDOOR UNIT										0										MOTORSMTCH	POWERED VIA OUTDOOR UNIT
MHP-4	MINISPLIT OUTDOOR UNIT	3880	208	1	1	18					3744	24	40	35	2	1	3	#8	#10	3/4"	BREAKER	
WM-4,1	MINISPLIT INDOOR UNIT										0										MOTORSMTCH	POWERED VIA OUTDOOR UNIT
OACU-1	OUTSIDE AIR UNIT COMPRESSOR	N/A	208	3	1	52.1					18770	57.9	80	80	3	1	3	#4	#8	1"	BREAKER	
OAU-1	OUTSIDE AIR UNIT AIR HANDLER	2000	208	1	1	7.3			7.3		1526	7.3	15	15	2	1	3	#12	#12	3/4"	BREAKER	
DDM	DISTILLATION DEIONIZATION MACHINE		208	1							8320	8320	40	50	2	1	3	#8	#10	3/4"	60/2/1	

SYSTEM		208/120V 3Φ 4W							
RATING		225A M.L.O. 22,000 AIC MINIMUM							
ENCLOSURE		NEMA1 SURFACE MOUNT							
OPTIONS BOLT ON BREAKERS									
CKT #	SERVING	CKT BKR		CONNECTED LOAD (VA)		CKT BKR		SERVING	CKT #
		TRIP	POLE	POLE	TRIP	POLE	TRIP		
1	REC - DIRECTORS OFFICE	20	1	1440	540	1	20	REC - WORK SUPPLY ROOM	2
3	REC - OPS MANAGER	20	1	900	720	1	20	REC - WORK SUPPLY ROOM	4
5	REC - FUTURE OFFICE	20	1	1080	1000	1	20	REC - WORK SUPPLY ROOM PRINTER	6
7	REC - OFFICE COORD.	20	1	900	1000	1	20	REC - WORK SUPPLY ROOM PRINTER	8
9	REC - ADMIN ASSISTANT	20	1	1080	900	1	20	REC - CONFERENCE ROOM	10
11	REC - ENTRY LOBBY	20	1	1080	720	1	20	REC - CONFERENCE ROOM	12
13	TRAP ROOM	20	1	1260	720	1	20	REC - MECH/FILE STORAGE/CORRIDOR	14
15	REC COORDIDOOOR	20	1	540	900	1	20	REC - OPERATOR OFFICE	16
17	REC - BOARDROOM	20	1	900	1080	1	20	REC - OPERATOR OFFICE	18
19	REC - BOARDROOM/CHAIR STO./COORDOR	20	1	1440	720	1	20	REC - MOSQUITO TECH	20
21	REC - WOMEN BATHROOM	20	1	720	540	1	20	REC - MEN BATHROOM	22
23	REC - EXTERIOR	20	1	900	720	1	20	REC - MOSQUITO TECH	24
25	ENT. OFFICE	20	1	1080	900	1	20	REC - MOSQUITO TECH	26
27	REC - COMM ROOM	20	1	1000	1080	1	20	REC - MOSQUITO TECH	28
29	REC - COMM ROOM	20	1	1000	1080	1	20	REC - FIELD SUPERVISOR	30
31	REC - COMM ROOM	20	1	1000	1080	1	20	REC - OPS PLANNING	32
33	REC - WATER FOUNTAIN	20	1	1000	1080	1	20	REC - KITCHEN	34
35	FIRE ALARM CONTROL PANEL (FACP)	20	*1	500	1000	1	20	REC - ICE MAKER	36
37	REC - SMALL APPLIANCE	20	1	360	360	1	20	SMALL APPLIANCE	38
39	REC - SMALL APPLIANCE	20	1	360	500	1	20	REC - GAS RANGE/HOOD	40
41	REC - REFRIG	20	1	500	1000	1	20	REC - DISPOSAL	42
43	REC - DISHWASHER	20	1	1000	360	1	20	REC - LAUNDRY	44
45	REC - WASHER	20	1	1000	1000	1	20	REC - WASHER	46
47	LTG - OFFICES, CORRIDOR, WORK/SUPPLY	20	1	1524	982	1	20	LTG - LOBBY, BREAKROOM	48
49	LTG - MEP, CONFERENCE, OFFICES	20	1	600	1229	1	20	LTG - CORR., IT, OFFICES	50
51	REC - MEZZANINE	20	1	360	550	1	20	LTG - PARKING LOT	52
53	REC - BOARDROOM	20	1	1440	360	1	20	REC - CONFERENCE ROOM	54
55	EXTERIOR FANS	20	1	1000	222	1	20	LTG - SECURITY	56
57	ACCESS CONTROL GATE	30	2	2000	360	1	20	REC - CONFERENCE ROOM	58
59	---	-	-	-	-	-	-	---	60
61	LTG - EXTERIOR	20	1	424	360	1	20	SMALL APPLIANCE	62
63	FLUORESCENT LIGHTING	20	1	600	720	1	20	FLR REC - MOSQUITO TECH	64
65	SPARE	20	1	-	720	1	20	FLR REC - MOSQUITO TECH	66
67	SPARE	20	1	-	720	1	20	FLR REC - OPERATOR OFFICE 017	68
69	SPARE	20	1	-	-	-	-	EXHAUST FAN	70
71	SPARE	20	1	-	-	-	-	---	72
73	DISTILLATION DEIONIZATION MACHINE	50	2	8320	1526	2	15	OAU-1	74
75	---	-	-	-	-	-	-	---	76
77	REC - DRYER	30	2	4992	-	1	-	SPACE ONLY	78
79	---	-	-	-	0	3	30</		

O'CONNELL & ASSOCIATES

CONSULTING ENGINEERS, LLC.

CERT. OF AUTH. #30549
1394 Co. Hwy. 283 S. Bldg. #3 Santa Rosa Beach FL, 32459
(850) 403-4555 www.oconnellengineers.com

JOB NAME: SWMCD

JOB NO.: 18178

TITLE: KNEEWALL ATTACHMENT

SHEET: SK-5

CALCULATED BY: JMB DRAWN BY: JMB

DATE: 12/17/2024

CHECKED BY: NOC

DATE: 12/17/20224

THIS ITEM HAS BEEN DIGITALLY SIGNED AND SEALED BY: JOSHUA M. BARKER, P.E. ON THE DATE SHOWN ON THE SIGNATURE. PRINTED COPIES OF THIS DOCUMENT ARE NOT CONSIDERED SIGNED AND SEALED AND THE SIGNATURE MUST BE VERIFIED ON ANY ELECTRONIC COPIES.

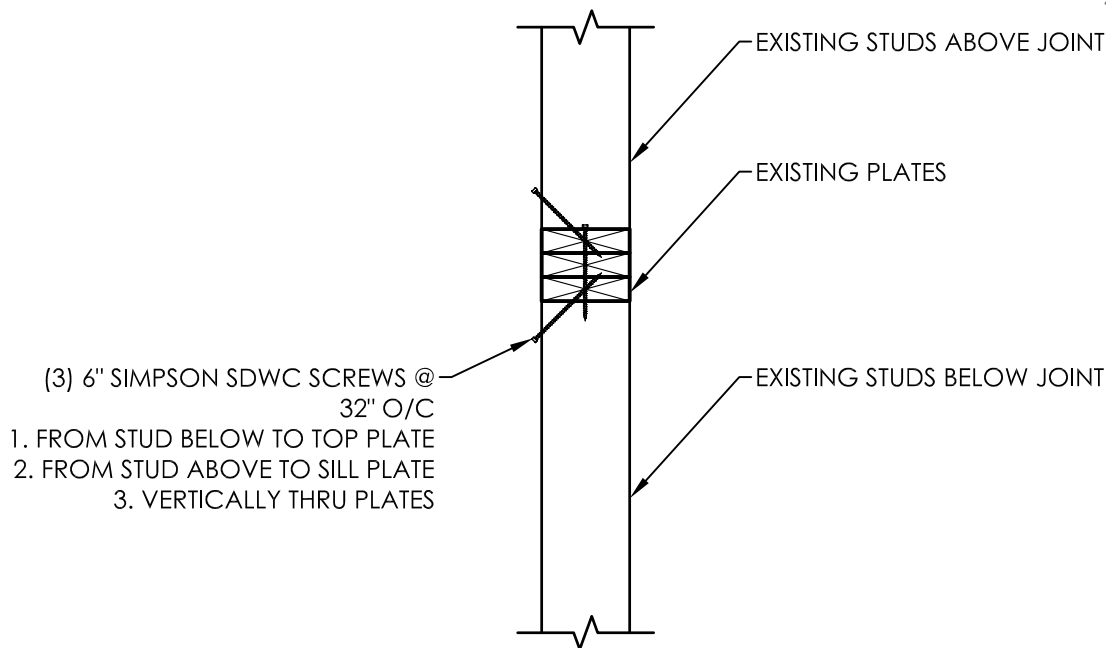
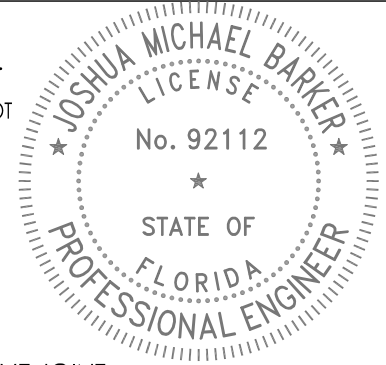

1
SK5

KNEEWALL

SCALE: N.T.S

PAGE 47 of 117

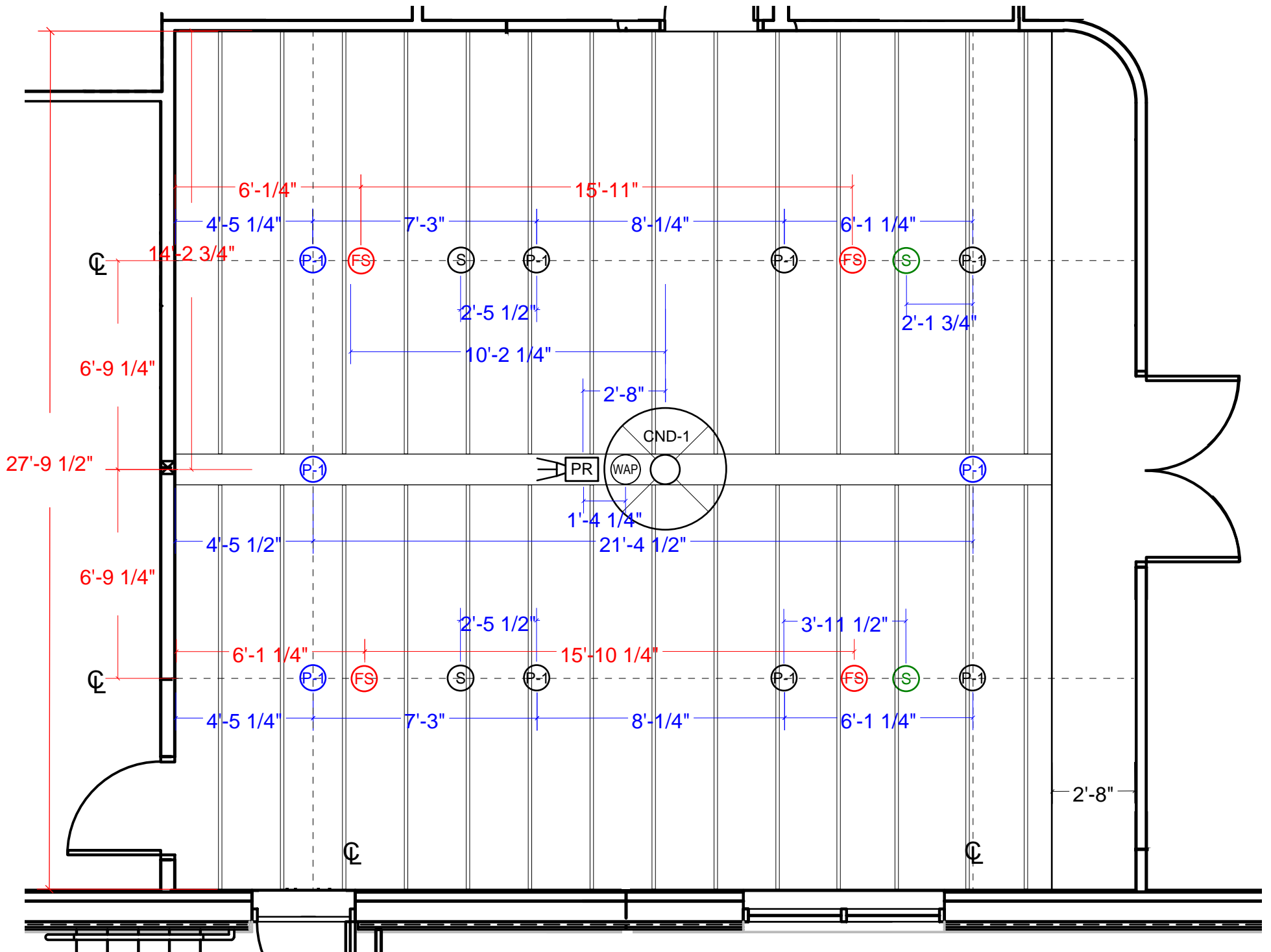

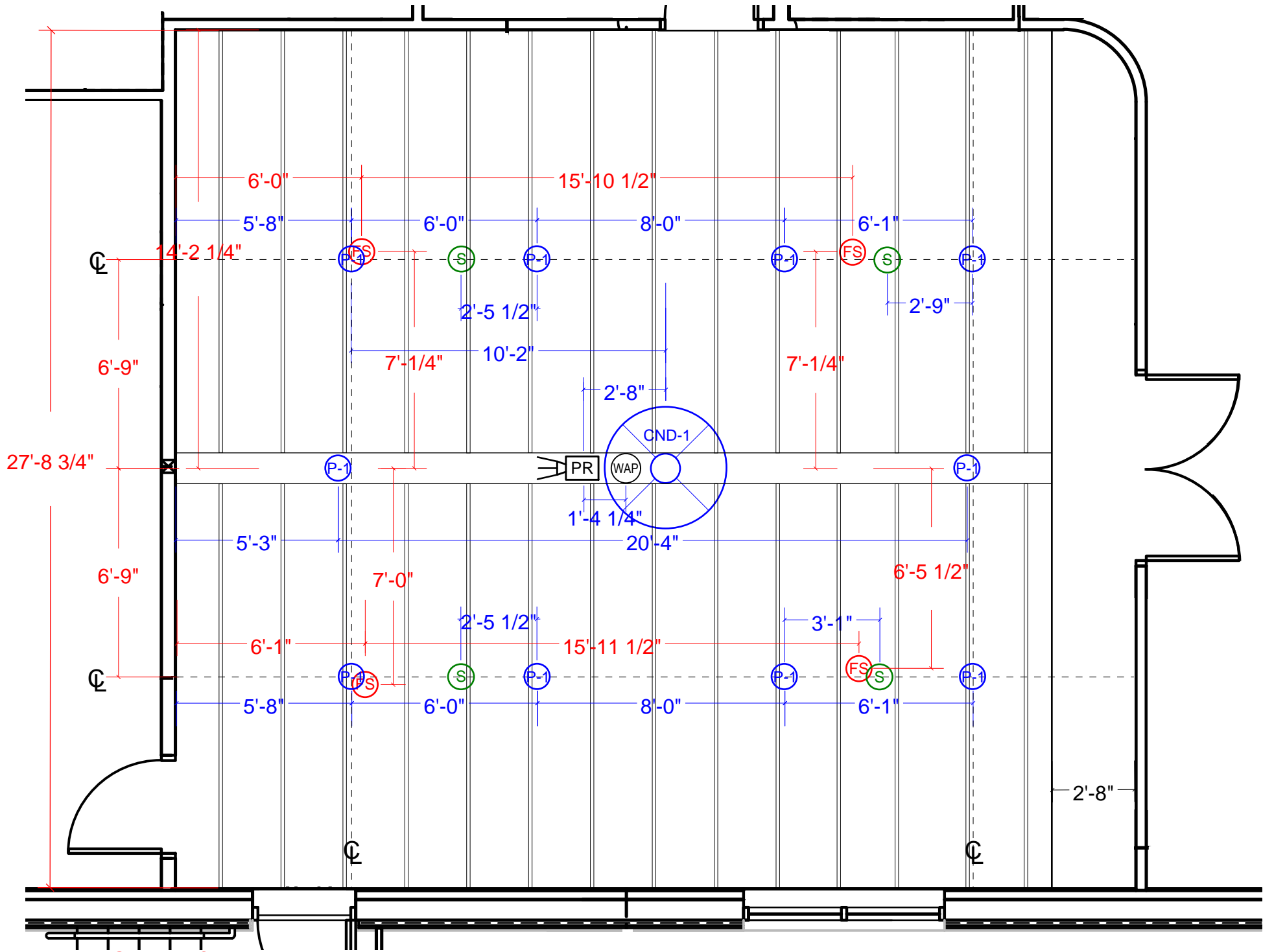

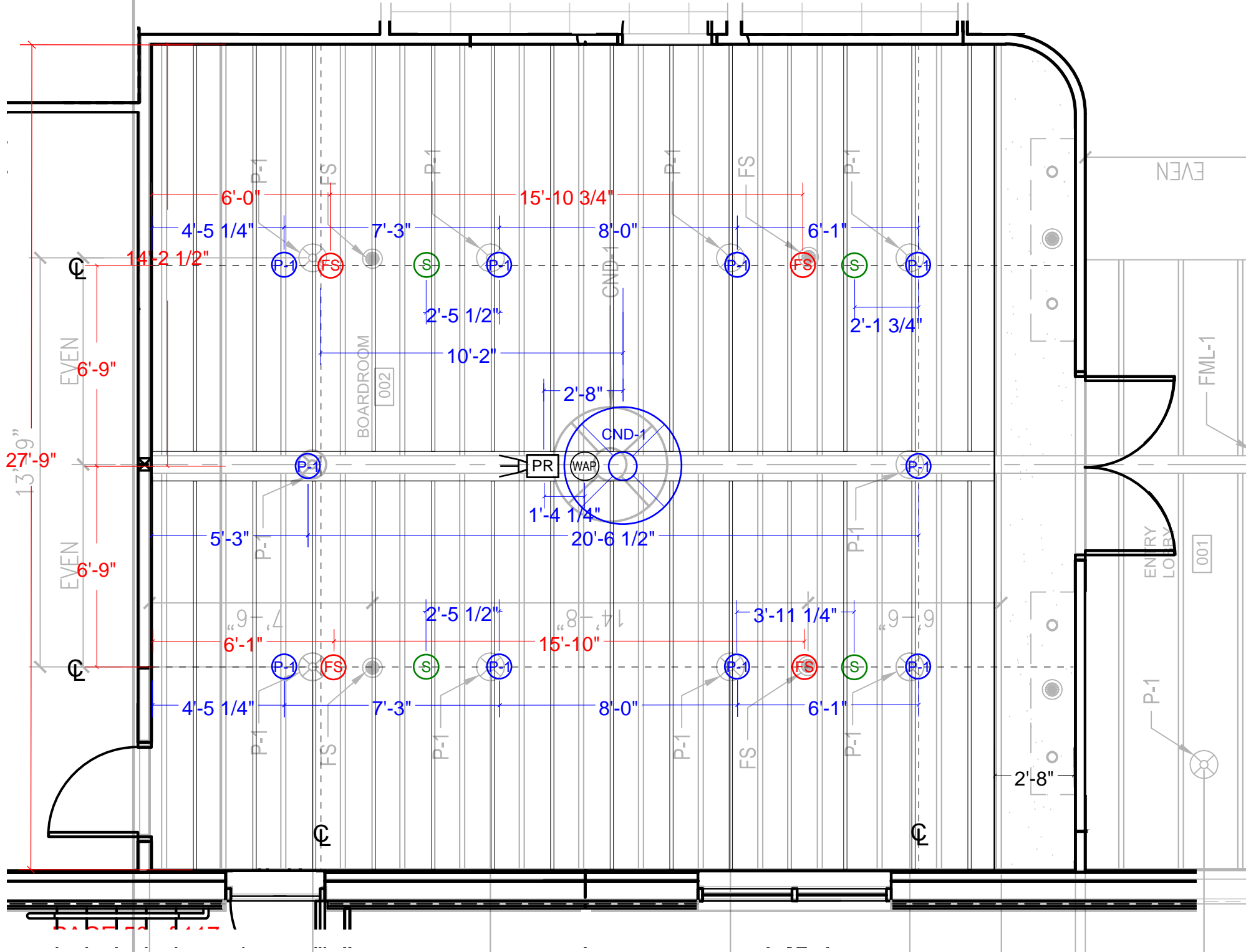

ALL REPORTS, PLANS, SPECIFICATIONS, COMPUTER FILES, FIELD DATA, NOTES AND OTHER DOCUMENTS AND INSTRUMENTS OF SERVICE SHALL REMAIN THE PROPERTY OF THE CONSULTANT. THE CONSULTANT SHALL RETAIN ALL COMMON LAW, STATUTORY AND OTHER RESERVED RIGHTS, INCLUDING THE COPYRIGHT THEREON. PURSUANT TO FLORIDA STATUTES, SECTION 558.0935, AN INDIVIDUAL EMPLOYEE OR AGENT MAY NOT BE HELD INDIVIDUALLY LIABLE FOR NEGLIGENCE.

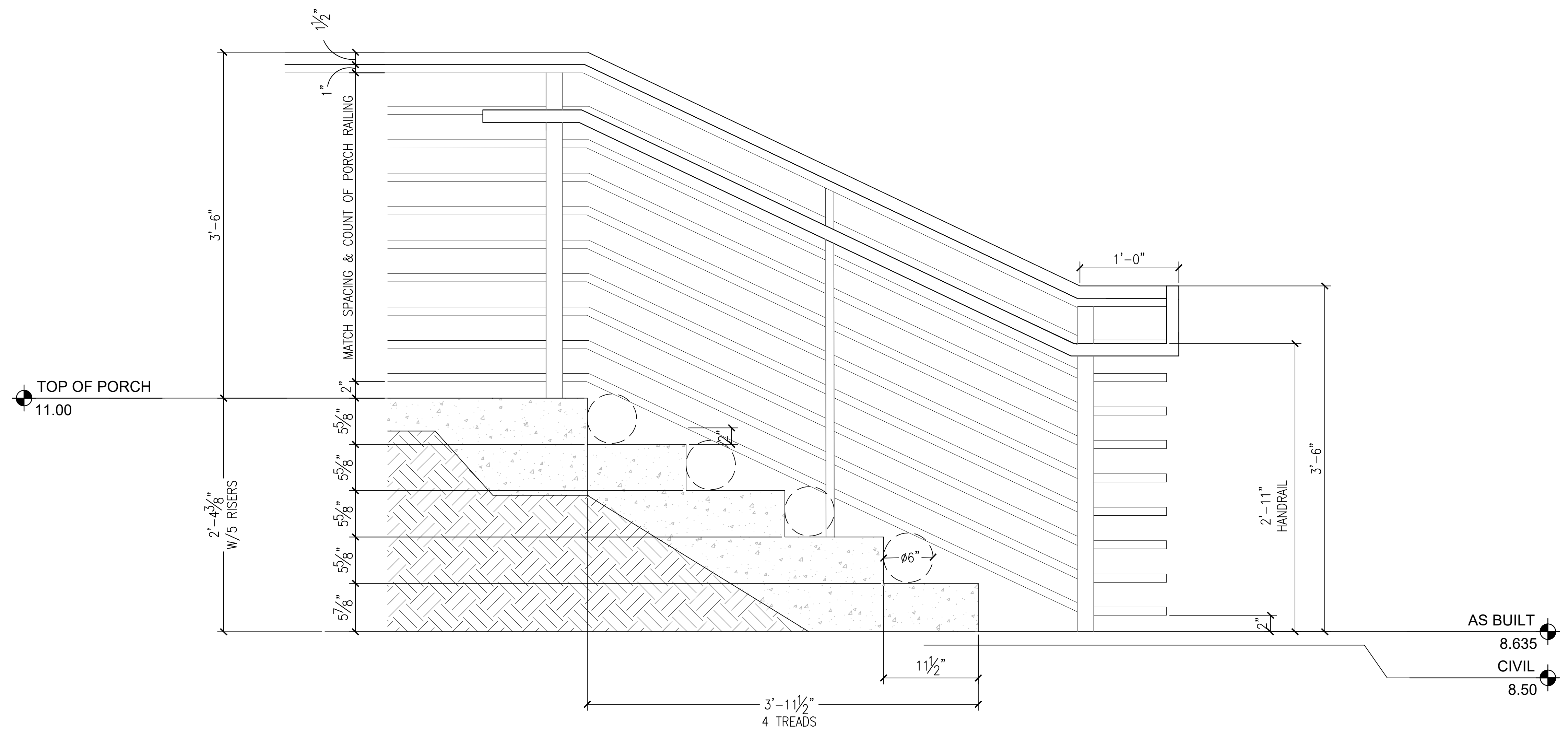

DAG ARCHITECTS
 DAG Architects, AAC000745
 1223 Airport Road Destin, Florida 32541
 850.837.8152 www.dagarchitects.com

**South Walton County Mosquito Control District
 New Headquarters Building**

774 North County Highway 393
 Santa Rosa Beach, Florida 32459

100%
 Construction
 Documents

No.	Description	Date

**Bridge
 Elevation/Sections**

Project number: 18106
 Date: 05-14-2025
 PIC: PLB
 PM: SLN

A1 TYPICAL STAIR AND RAILING

SCALE: 1 1/2"=1'-0"

ASI #12

EXHIBIT C

18106 South Walton County Mosquito Control District New Headquarters				
Service Order #4 - Admin Bldg Construction Documents, Bidding, CA				
Construction Administration				
Labor Group: Employee Type/Employee/Activity	Cost	Spent	Billed	Billed
Expense & Consultant Group: Type/Vendor/Activity	Hrs/Units	Amount	Hrs/Units	Amount
Labor	1,005.30	115,747.00	647.90	35,649.00
Billed as Fee	0.00	0.00	0.00	35,649.00
Principal III	37.50	10,312.50	20.50	0.00
Design Staff II	503.00	55,330.00	189.75	0.00
Design Staff I	85.15	8,089.25	68.50	0.00
Construction Administrator I	66.50	8,312.50	62.00	0.00
Administration II	5.50	330.00		0.00
Administration I	0.50	30.00		0.00
Senior Principal	6.50	1,787.50	6.50	0.00
Interior Designer	10.90	926.50	10.90	0.00
Architectural Staff	253.50	27,885.00	253.50	0.00
Associate Architectural Staff	1.25	118.75	1.25	0.00
Intern Architect	35.00	2,625.00	35.00	0.00
Expense		1,323.99		0.00
Jennifer P. Langham		16.08		0.00
Steven L. Nicholson		1,307.91		0.00
Consultant		12,960.09		23,940.00
Billed as Fee		0.00		23,940.00
O'Connell & Associates Consulting Engineers, LLC		8,760.09		0.00
Watford Engineering, Inc.		4,200.00		0.00
	1,005.30	130,031.08	647.90	59,589.00
Total Overage in hours				70,412.00

Project	Description	Dollars				Hours			
		Contract	Billed	WIP	Spent	Budget	Billed	WIP	Spent
	Construction Administration	59,589	59,589	0	130,031	285	648	0	1,005
	<u>Detail</u>								
	Overage hrs								720

Date	Project Description	Phase ID & Description	Employee	Units/Hours	Billed Rate	Spent Amount	Notes
7/7/2023	South Walton County Mosquito Control District New Headquarters	Service Order #4 - Admin Bldg Construction Documents, Bidding, CA Construction Administration	Steven Nicholson	1.00	110.00	110.00	coordination items
11/10/2023	South Walton County Mosquito Control District New Headquarters	Service Order #4 - Admin Bldg Construction Documents, Bidding, CA Construction Administration	Alex Gacic	2.00	125.00	250.00	Review heandrail requirements for exterior sidewalk stairs
11/30/2023	South Walton County Mosquito Control District New Headquarters	Service Order #4 - Admin Bldg Construction Documents, Bidding, CA Construction Administration	Steven Nicholson	2.00	110.00	220.00	update roof slopes for contractorcoordinate owner furnished contractor installed
12/5/2023	South Walton County Mosquito Control District New Headquarters	Service Order #4 - Admin Bldg Construction Documents, Bidding, CA Construction Administration	Alex Gacic	1.00	125.00	125.00	Follpw up on geotech reports clarification of bearing capacity
12/21/2023	South Walton County Mosquito Control District New Headquarters	Service Order #4 - Admin Bldg Construction Documents, Bidding, CA Construction Administration	Alex Gacic	3.00	125.00	375.00	Review of CM budget estimates, compare with Flre Station project
1/15/2024	South Walton County Mosquito Control District New Headquarters	Service Order #4 - Admin Bldg Construction Documents, Bidding, CA Construction Administration	Steven Nicholson	1.50	110.00	165.00	check all drawings to make sure contractor has most current set
1/18/2024	South Walton County Mosquito Control District New Headquarters	Service Order #4 - Admin Bldg Construction Documents, Bidding, CA Construction Administration	Steven Nicholson	3.00	110.00	330.00	Phase II discussion and planning
1/23/2024	South Walton County Mosquito Control District New Headquarters	Service Order #4 - Admin Bldg Construction Documents, Bidding, CA Construction Administration	Jennifer Langham	0.15	85.00	12.75	RFI material check
1/23/2024	South Walton County Mosquito Control District New Headquarters	Service Order #4 - Admin Bldg Construction Documents, Bidding, CA Construction Administration	Steven Nicholson	1.50	110.00	165.00	RFI answers and conversations
1/30/2024	South Walton County Mosquito Control District New Headquarters	Service Order #4 - Admin Bldg Construction Documents, Bidding, CA Construction Administration	Steven Nicholson	1.00	110.00	110.00	RFIs
1/31/2024	South Walton County Mosquito Control District New Headquarters	Service Order #4 - Admin Bldg Construction Documents, Bidding, CA Construction Administration	Jennifer Langham	0.50	85.00	42.50	answering questions in RFI's
2/1/2024	South Walton County Mosquito Control District New Headquarters	Service Order #4 - Admin Bldg Construction Documents, Bidding, CA Construction Administration	Jennifer Langham	0.50	85.00	42.50	answering RFI questions
2/1/2024	South Walton County Mosquito Control District New Headquarters	Service Order #4 - Admin Bldg Construction Documents, Bidding, CA Construction Administration	Steven Nicholson	2.00	110.00	220.00	RFI #2
2/2/2024	South Walton County Mosquito Control District New Headquarters	Service Order #4 - Admin Bldg Construction Documents, Bidding, CA Construction Administration	Steven Nicholson	4.00	110.00	440.00	RFI #2, 3 & 4
2/5/2024	South Walton County Mosquito Control District New Headquarters	Service Order #4 - Admin Bldg Construction Documents, Bidding, CA Construction Administration	Steven Nicholson	3.50	110.00	385.00	answering RFI's #3 & 4
2/6/2024	South Walton County Mosquito Control District New Headquarters	Service Order #4 - Admin Bldg Construction Documents, Bidding, CA Construction Administration	Steven Nicholson	4.00	110.00	440.00	answering RFI's #3,4,5,6,&7begin Revision 2
2/8/2024	South Walton County Mosquito Control District New Headquarters	Service Order #4 - Admin Bldg Construction Documents, Bidding, CA Construction Administration	Jennifer Langham	1.00	85.00	85.00	making changes for revision 2 based off of RFI's
2/8/2024	South Walton County Mosquito Control District New Headquarters	Service Order #4 - Admin Bldg Construction Documents, Bidding, CA Construction Administration	Patrick Ballasch	0.50	275.00	137.50	review details
2/8/2024	South Walton County Mosquito Control District New Headquarters	Service Order #4 - Admin Bldg Construction Documents, Bidding, CA Construction Administration	Steven Nicholson	4.00	110.00	440.00	answering RFI's # 5,6,7,8coordinate with electrical and fire protection.
2/12/2024	South Walton County Mosquito Control District New Headquarters	Service Order #4 - Admin Bldg Construction Documents, Bidding, CA Construction Administration	Steven Nicholson	1.00	110.00	110.00	answering RFI's #8,9,10
2/13/2024	South Walton County Mosquito Control District New Headquarters	Service Order #4 - Admin Bldg Construction Documents, Bidding, CA Construction Administration	Alex Gacic	1.00	125.00	125.00	Project Meeting
2/15/2024	South Walton County Mosquito Control District New Headquarters	Service Order #4 - Admin Bldg Construction Documents, Bidding, CA Construction Administration	Steven Nicholson	2.00	110.00	220.00	answering RFI's # 10,11
2/15/2024	South Walton County Mosquito Control District New Headquarters	Service Order #4 - Admin Bldg Construction Documents, Bidding, CA Construction Administration	Jennifer Langham	0.50	85.00	42.50	answering RFI questions
2/16/2024	South Walton County Mosquito Control District New Headquarters	Service Order #4 - Admin Bldg Construction Documents, Bidding, CA Construction Administration	Steven Nicholson	1.00	110.00	110.00	meeting for RFI #011 with Civil and FP
2/19/2024	South Walton County Mosquito Control District New Headquarters	Service Order #4 - Admin Bldg Construction Documents, Bidding, CA Construction Administration	Steven Nicholson	2.00	110.00	220.00	RFI # 10 & 11
2/20/2024	South Walton County Mosquito Control District New Headquarters	Service Order #4 - Admin Bldg Construction Documents, Bidding, CA Construction Administration	Steven Nicholson	2.50	110.00	275.00	truss issue from vendorfix roof plan
2/22/2024	South Walton County Mosquito Control District New Headquarters	Service Order #4 - Admin Bldg Construction Documents, Bidding, CA Construction Administration	Steven Nicholson	3.00	110.00	330.00	truss issue from vendorfix roof plan
2/26/2024	South Walton County Mosquito Control District New Headquarters	Service Order #4 - Admin Bldg Construction Documents, Bidding, CA Construction Administration	Steven Nicholson	1.00	110.00	110.00	RFI #12 & 13 coordinate with consultants
2/27/2024	South Walton County Mosquito Control District New Headquarters	Service Order #4 - Admin Bldg Construction Documents, Bidding, CA Construction Administration	Steven Nicholson	1.00	110.00	110.00	RFI #13
2/29/2024	South Walton County Mosquito Control District New Headquarters	Service Order #4 - Admin Bldg Construction Documents, Bidding, CA Construction Administration	Steven Nicholson	2.50	110.00	275.00	reviewed structural comments and finalized and delivered Revision 3 Roof plan and returned RFI #13

3/4/2024	South Walton County Mosquito Control District New Headquarters	Service Order #4 - Admin Bldg Construction Documents, Bidding, CA Construction Administration	Steven Nicholson	2.00	110.00	220.00 RFI #11 & 14 work on answers and revisions
3/5/2024	South Walton County Mosquito Control District New Headquarters	Service Order #4 - Admin Bldg Construction Documents, Bidding, CA Construction Administration	Steven Nicholson	2.00	110.00	220.00 RFI # 11,13 & 14
3/6/2024	South Walton County Mosquito Control District New Headquarters	Service Order #4 - Admin Bldg Construction Documents, Bidding, CA Construction Administration	Jennifer Langham	1.00	85.00	85.00 answering RFI's
3/6/2024	South Walton County Mosquito Control District New Headquarters	Service Order #4 - Admin Bldg Construction Documents, Bidding, CA Construction Administration	Steven Nicholson	2.50	110.00	275.00 Pre Construction meeting with Owner, contractor and county
3/7/2024	South Walton County Mosquito Control District New Headquarters	Service Order #4 - Admin Bldg Construction Documents, Bidding, CA Construction Administration	Caroline Henderson	0.75	95.00	71.25 - Finish Floor Plan/ Interior Elevations - Helping Jenny w/ CAD issues - Making edits
3/7/2024	South Walton County Mosquito Control District New Headquarters	Service Order #4 - Admin Bldg Construction Documents, Bidding, CA Construction Administration	Steven Nicholson	2.00	110.00	220.00 RFI # 14 & 15
3/8/2024	South Walton County Mosquito Control District New Headquarters	Service Order #4 - Admin Bldg Construction Documents, Bidding, CA Construction Administration	Jennifer Langham	0.25	85.00	21.25 Answering RFI
3/8/2024	South Walton County Mosquito Control District New Headquarters	Service Order #4 - Admin Bldg Construction Documents, Bidding, CA Construction Administration	Steven Nicholson	3.00	110.00	330.00 RFI # 14 & 15
3/11/2024	South Walton County Mosquito Control District New Headquarters	Service Order #4 - Admin Bldg Construction Documents, Bidding, CA Construction Administration	Alex Gacic	1.00	125.00	125.00 Project meeting
3/11/2024	South Walton County Mosquito Control District New Headquarters	Service Order #4 - Admin Bldg Construction Documents, Bidding, CA Construction Administration	Steven Nicholson	2.50	110.00	275.00 Precon meeting with owner and contractor
3/12/2024	South Walton County Mosquito Control District New Headquarters	Service Order #4 - Admin Bldg Construction Documents, Bidding, CA Construction Administration	Jennifer Langham	1.00	85.00	85.00 stainless steel spec for RFI
3/13/2024	South Walton County Mosquito Control District New Headquarters	Service Order #4 - Admin Bldg Construction Documents, Bidding, CA Construction Administration	Steven Nicholson	1.00	110.00	110.00 RFI answers and coordination
3/14/2024	South Walton County Mosquito Control District New Headquarters	Service Order #4 - Admin Bldg Construction Documents, Bidding, CA Construction Administration	Steven Nicholson	1.50	110.00	165.00 RFI answers and coordination
3/15/2024	South Walton County Mosquito Control District New Headquarters	Service Order #4 - Admin Bldg Construction Documents, Bidding, CA Construction Administration	Steven Nicholson	1.00	110.00	110.00 RFI answers and coordination
3/18/2024	South Walton County Mosquito Control District New Headquarters	Service Order #4 - Admin Bldg Construction Documents, Bidding, CA Construction Administration	Caroline Henderson	0.50	95.00	47.50 - CAD Edits
3/18/2024	South Walton County Mosquito Control District New Headquarters	Service Order #4 - Admin Bldg Construction Documents, Bidding, CA Construction Administration	Steven Nicholson	1.50	110.00	165.00 GMP Review meeting with Owner and Contractor
3/19/2024	South Walton County Mosquito Control District New Headquarters	Service Order #4 - Admin Bldg Construction Documents, Bidding, CA Construction Administration	Jennifer Langham	5.00	85.00	425.00 casework specifications answering RFI's
3/19/2024	South Walton County Mosquito Control District New Headquarters	Service Order #4 - Admin Bldg Construction Documents, Bidding, CA Construction Administration	Steven Nicholson	2.00	110.00	220.00 review GMP and mark up issues before board meeting
3/20/2024	South Walton County Mosquito Control District New Headquarters	Service Order #4 - Admin Bldg Construction Documents, Bidding, CA Construction Administration	Jennifer Langham	1.00	85.00	85.00 conference room elevation for revision 6
3/21/2024	South Walton County Mosquito Control District New Headquarters	Service Order #4 - Admin Bldg Construction Documents, Bidding, CA Construction Administration	Steven Nicholson	4.00	110.00	440.00 Board meeting to approve GMP
3/22/2024	South Walton County Mosquito Control District New Headquarters	Service Order #4 - Admin Bldg Construction Documents, Bidding, CA Construction Administration	Steven Nicholson	2.00	110.00	220.00 RFIs start furn down in boardroom section
3/25/2024	South Walton County Mosquito Control District New Headquarters	Service Order #4 - Admin Bldg Construction Documents, Bidding, CA Construction Administration	Patrick Ballasch	1.00	275.00	275.00 meeting w stakeholders
3/25/2024	South Walton County Mosquito Control District New Headquarters	Service Order #4 - Admin Bldg Construction Documents, Bidding, CA Construction Administration	Steven Nicholson	1.50	110.00	165.00 OAC meeting
3/26/2024	South Walton County Mosquito Control District New Headquarters	Service Order #4 - Admin Bldg Construction Documents, Bidding, CA Construction Administration	Steven Nicholson	3.00	110.00	330.00 working on revision 6 discuss site issues and phasing with contractor
3/28/2024	South Walton County Mosquito Control District New Headquarters	Service Order #4 - Admin Bldg Construction Documents, Bidding, CA Construction Administration	Steven Nicholson	1.50	110.00	165.00 site phasing discussion set up meeting for April 1st
3/29/2024	South Walton County Mosquito Control District New Headquarters	Service Order #4 - Admin Bldg Construction Documents, Bidding, CA Construction Administration	Jonah Novack	1.00	85.00	85.00 SKETCHUP
4/1/2024	South Walton County Mosquito Control District New Headquarters	Service Order #4 - Admin Bldg Construction Documents, Bidding, CA Construction Administration	Jonah Novack	6.50	85.00	552.50 sketchup
4/1/2024	South Walton County Mosquito Control District New Headquarters	Service Order #4 - Admin Bldg Construction Documents, Bidding, CA Construction Administration	Steven Nicholson	3.00	110.00	330.00 Rev 6 bridge decking and railing presentation coordinate with Yona on model
4/2/2024	South Walton County Mosquito Control District New Headquarters	Service Order #4 - Admin Bldg Construction Documents, Bidding, CA Construction Administration	Jonah Novack	6.00	85.00	510.00 sketchup and rendering
4/2/2024	South Walton County Mosquito Control District New Headquarters	Service Order #4 - Admin Bldg Construction Documents, Bidding, CA Construction Administration	Steven Nicholson	2.50	110.00	275.00 casework spec and info sent off to contractor furn down in boardroom
4/3/2024	South Walton County Mosquito Control District New Headquarters	Service Order #4 - Admin Bldg Construction Documents, Bidding, CA Construction Administration	Jonah Novack	3.75	85.00	318.75 rendering

4/3/2024	South Walton County Mosquito Control District New Headquarters	Service Order #4 - Admin Bldg Construction Documents, Bidding, CA Construction Administration	Patrick Ballasch	1.00	275.00	275.00	review interior
4/4/2024	South Walton County Mosquito Control District New Headquarters	Service Order #4 - Admin Bldg Construction Documents, Bidding, CA Construction Administration	Jonah Novack	4.00	85.00	340.00	renders
4/4/2024	South Walton County Mosquito Control District New Headquarters	Service Order #4 - Admin Bldg Construction Documents, Bidding, CA Construction Administration	Patrick Ballasch	1.00	275.00	275.00	review interior, railings
4/5/2024	South Walton County Mosquito Control District New Headquarters	Service Order #4 - Admin Bldg Construction Documents, Bidding, CA Construction Administration	Jonah Novack	1.00	85.00	85.00	renders
4/8/2024	South Walton County Mosquito Control District New Headquarters	Service Order #4 - Admin Bldg Construction Documents, Bidding, CA Construction Administration	Steven Nicholson	2.00	110.00	220.00	Revise 6 items
4/9/2024	South Walton County Mosquito Control District New Headquarters	Service Order #4 - Admin Bldg Construction Documents, Bidding, CA Construction Administration	Jonah Novack	7.75	85.00	658.75	rendering
4/9/2024	South Walton County Mosquito Control District New Headquarters	Service Order #4 - Admin Bldg Construction Documents, Bidding, CA Construction Administration	Patrick Ballasch	1.00	275.00	275.00	OAC
4/9/2024	South Walton County Mosquito Control District New Headquarters	Service Order #4 - Admin Bldg Construction Documents, Bidding, CA Construction Administration	Steven Nicholson	1.00	110.00	110.00	Weekly OAC meeting
4/10/2024	South Walton County Mosquito Control District New Headquarters	Service Order #4 - Admin Bldg Construction Documents, Bidding, CA Construction Administration	Jonah Novack	5.00	95.00	475.00	renders
4/10/2024	South Walton County Mosquito Control District New Headquarters	Service Order #4 - Admin Bldg Construction Documents, Bidding, CA Construction Administration	Steven Nicholson	1.50	110.00	165.00	Revise 6 items
4/11/2024	South Walton County Mosquito Control District New Headquarters	Service Order #4 - Admin Bldg Construction Documents, Bidding, CA Construction Administration	Steven Nicholson	3.00	110.00	330.00	Revision 6 drawings and updates
4/12/2024	South Walton County Mosquito Control District New Headquarters	Service Order #4 - Admin Bldg Construction Documents, Bidding, CA Construction Administration	Patrick Ballasch	1.00	275.00	275.00	railing detailing
4/12/2024	South Walton County Mosquito Control District New Headquarters	Service Order #4 - Admin Bldg Construction Documents, Bidding, CA Construction Administration	Steven Nicholson	6.00	110.00	660.00	Bridge enlarged plan bridge railing elevation and sections discuss with Pat Revision 6 items
4/15/2024	South Walton County Mosquito Control District New Headquarters	Service Order #4 - Admin Bldg Construction Documents, Bidding, CA Construction Administration	Steven Nicholson	1.50	110.00	165.00	revision #6
4/16/2024	South Walton County Mosquito Control District New Headquarters	Service Order #4 - Admin Bldg Construction Documents, Bidding, CA Construction Administration	Steven Nicholson	4.00	110.00	440.00	revision #6 bridge elevations and sections
4/18/2024	South Walton County Mosquito Control District New Headquarters	Service Order #4 - Admin Bldg Construction Documents, Bidding, CA Construction Administration	Patrick Ballasch	1.00	275.00	275.00	review rail detail
4/18/2024	South Walton County Mosquito Control District New Headquarters	Service Order #4 - Admin Bldg Construction Documents, Bidding, CA Construction Administration	Steven Nicholson	5.00	110.00	550.00	Revision #6 Bridge elevations and sections railing detail
4/19/2024	South Walton County Mosquito Control District New Headquarters	Service Order #4 - Admin Bldg Construction Documents, Bidding, CA Construction Administration	Steven Nicholson	4.00	110.00	440.00	revision 6 plot all sheets combine architectural start full combined set
4/22/2024	South Walton County Mosquito Control District New Headquarters	Service Order #4 - Admin Bldg Construction Documents, Bidding, CA Construction Administration	Steven Nicholson	2.00	110.00	220.00	compile all drawings and revisions for the 100% CDs for finalizing permitting
4/23/2024	South Walton County Mosquito Control District New Headquarters	Service Order #4 - Admin Bldg Construction Documents, Bidding, CA Construction Administration	Steven Nicholson	2.00	110.00	220.00	OAC meeting
4/23/2024	South Walton County Mosquito Control District New Headquarters	Service Order #4 - Admin Bldg Construction Documents, Bidding, CA Construction Administration	Patrick Ballasch	1.00	275.00	275.00	review lighting
4/24/2024	South Walton County Mosquito Control District New Headquarters	Service Order #4 - Admin Bldg Construction Documents, Bidding, CA Construction Administration	Steven Nicholson	1.00	110.00	110.00	compile in structural drawings for 100% CDs
4/25/2024	South Walton County Mosquito Control District New Headquarters	Service Order #4 - Admin Bldg Construction Documents, Bidding, CA Construction Administration	Steven Nicholson	2.00	110.00	220.00	received rebar submittal look over submittal log to review
4/25/2024	South Walton County Mosquito Control District New Headquarters	Service Order #4 - Admin Bldg Construction Documents, Bidding, CA Construction Administration	Patrick Ballasch	3.50	275.00	962.50	ground breaking
4/29/2024	South Walton County Mosquito Control District New Headquarters	Service Order #4 - Admin Bldg Construction Documents, Bidding, CA Construction Administration	Steven Nicholson	1.50	110.00	165.00	go over submittal log
4/30/2024	South Walton County Mosquito Control District New Headquarters	Service Order #4 - Admin Bldg Construction Documents, Bidding, CA Construction Administration	Alex Gacic	1.00	125.00	125.00	Project Meeting
4/30/2024	South Walton County Mosquito Control District New Headquarters	Service Order #4 - Admin Bldg Construction Documents, Bidding, CA Construction Administration	Steven Nicholson	3.00	110.00	330.00	OAC meeting travel time go over submittals
5/2/2024	South Walton County Mosquito Control District New Headquarters	Service Order #4 - Admin Bldg Construction Documents, Bidding, CA Construction Administration	Steven Nicholson	1.00	110.00	110.00	submittals
5/3/2024	South Walton County Mosquito Control District New Headquarters	Service Order #4 - Admin Bldg Construction Documents, Bidding, CA Construction Administration	Alex Gacic	1.00	125.00	125.00	Review Minutes and plan review
5/6/2024	South Walton County Mosquito Control District New Headquarters	Service Order #4 - Admin Bldg Construction Documents, Bidding, CA Construction Administration	Alex Gacic	2.00	125.00	250.00	Shower coordination and termite control spec
5/6/2024	South Walton County Mosquito Control District New Headquarters	Service Order #4 - Admin Bldg Construction Documents, Bidding, CA Construction Administration	Steven Nicholson	2.00	110.00	220.00	review and send out submittals update submittal log answer RFI in RedTeam

5/7/2024	South Walton County Mosquito Control District New Headquarters	Service Order #4 - Admin Bldg Construction Documents, Bidding, CA Construction Administration	Alex Gacic	1.00	125.00	125.00 Project Meeting
5/7/2024	South Walton County Mosquito Control District New Headquarters	Service Order #4 - Admin Bldg Construction Documents, Bidding, CA Construction Administration	Steven Nicholson	3.50	110.00	385.00 OAC meetingreview and send out submittals
5/9/2024	South Walton County Mosquito Control District New Headquarters	Service Order #4 - Admin Bldg Construction Documents, Bidding, CA Construction Administration	Steven Nicholson	2.00	110.00	220.00 review and send out submittals
5/10/2024	South Walton County Mosquito Control District New Headquarters	Service Order #4 - Admin Bldg Construction Documents, Bidding, CA Construction Administration	Steven Nicholson	1.00	110.00	110.00 review and send out submittals
5/13/2024	South Walton County Mosquito Control District New Headquarters	Service Order #4 - Admin Bldg Construction Documents, Bidding, CA Construction Administration	Steven Nicholson	1.00	110.00	110.00 Review and send out submittals
5/14/2024	South Walton County Mosquito Control District New Headquarters	Service Order #4 - Admin Bldg Construction Documents, Bidding, CA Construction Administration	Steven Nicholson	2.00	110.00	220.00 OAC meeting submittals
5/15/2024	South Walton County Mosquito Control District New Headquarters	Service Order #4 - Admin Bldg Construction Documents, Bidding, CA Construction Administration	Steven Nicholson	2.00	110.00	220.00 Review submittals and send out for reveiw
5/16/2024	South Walton County Mosquito Control District New Headquarters	Service Order #4 - Admin Bldg Construction Documents, Bidding, CA Construction Administration	Steven Nicholson	1.00	110.00	110.00 Review submittals and send out for reveiw
5/17/2024	South Walton County Mosquito Control District New Headquarters	Service Order #4 - Admin Bldg Construction Documents, Bidding, CA Construction Administration	Steven Nicholson	5.00	110.00	550.00 Review submittals storefront and glass - make mark upsrevision #7 update door schedule and door frames with dimensionsReview colors for glass, roof and exterior
5/20/2024	South Walton County Mosquito Control District New Headquarters	Service Order #4 - Admin Bldg Construction Documents, Bidding, CA Construction Administration	Steven Nicholson	1.00	110.00	110.00 Review submittals and logs
5/21/2024	South Walton County Mosquito Control District New Headquarters	Service Order #4 - Admin Bldg Construction Documents, Bidding, CA Construction Administration	Alex Gacic	1.00	125.00	125.00 Project Meeting
5/21/2024	South Walton County Mosquito Control District New Headquarters	Service Order #4 - Admin Bldg Construction Documents, Bidding, CA Construction Administration	Steven Nicholson	3.00	110.00	330.00 OAC meeting Submittals
5/22/2024	South Walton County Mosquito Control District New Headquarters	Service Order #4 - Admin Bldg Construction Documents, Bidding, CA Construction Administration	Steven Nicholson	2.00	110.00	220.00 Review submittals and logs
5/23/2024	South Walton County Mosquito Control District New Headquarters	Service Order #4 - Admin Bldg Construction Documents, Bidding, CA Construction Administration	Alex Gacic	2.00	125.00	250.00 Door hardware submittal
5/23/2024	South Walton County Mosquito Control District New Headquarters	Service Order #4 - Admin Bldg Construction Documents, Bidding, CA Construction Administration	Steven Nicholson	2.00	110.00	220.00 Review submittals and logsreview pay app
5/24/2024	South Walton County Mosquito Control District New Headquarters	Service Order #4 - Admin Bldg Construction Documents, Bidding, CA Construction Administration	Steven Nicholson	1.00	110.00	110.00 Review submittals and logs
5/24/2024	South Walton County Mosquito Control District New Headquarters	Service Order #4 - Admin Bldg Construction Documents, Bidding, CA Construction Administration	Alex Gacic	2.00	125.00	250.00 Door hardware submittal
5/28/2024	South Walton County Mosquito Control District New Headquarters	Service Order #4 - Admin Bldg Construction Documents, Bidding, CA Construction Administration	Steven Nicholson	1.50	110.00	165.00 review submittals update submittal log
5/30/2024	South Walton County Mosquito Control District New Headquarters	Service Order #4 - Admin Bldg Construction Documents, Bidding, CA Construction Administration	Jennifer Langham	0.50	85.00	42.50 exterior color selection
5/30/2024	South Walton County Mosquito Control District New Headquarters	Service Order #4 - Admin Bldg Construction Documents, Bidding, CA Construction Administration	Steven Nicholson	3.00	110.00	330.00 review submittals update submittal log
5/31/2024	South Walton County Mosquito Control District New Headquarters	Service Order #4 - Admin Bldg Construction Documents, Bidding, CA Construction Administration	Steven Nicholson	4.50	110.00	495.00 work on submittalsStart ASI 001 - storefront transom detail with 10' ceiling
6/3/2024	South Walton County Mosquito Control District New Headquarters	Service Order #4 - Admin Bldg Construction Documents, Bidding, CA Construction Administration	Jennifer Langham	2.00	85.00	170.00 flooring submittal
6/3/2024	South Walton County Mosquito Control District New Headquarters	Service Order #4 - Admin Bldg Construction Documents, Bidding, CA Construction Administration	Alex Gacic	2.00	125.00	250.00 hardware submittal
6/4/2024	South Walton County Mosquito Control District New Headquarters	Service Order #4 - Admin Bldg Construction Documents, Bidding, CA Construction Administration	Alex Gacic	3.00	125.00	375.00 project meeting,fire sprinkler shop dwgs
6/4/2024	South Walton County Mosquito Control District New Headquarters	Service Order #4 - Admin Bldg Construction Documents, Bidding, CA Construction Administration	Steven Nicholson	4.00	110.00	440.00 OAC meeting work on submittals and log
6/5/2024	South Walton County Mosquito Control District New Headquarters	Service Order #4 - Admin Bldg Construction Documents, Bidding, CA Construction Administration	Alex Gacic	7.00	125.00	875.00 Project Meeting and submittal coordination
6/5/2024	South Walton County Mosquito Control District New Headquarters	Service Order #4 - Admin Bldg Construction Documents, Bidding, CA Construction Administration	Jennifer Langham	0.50	85.00	42.50 electrical outlet location plan
6/5/2024	South Walton County Mosquito Control District New Headquarters	Service Order #4 - Admin Bldg Construction Documents, Bidding, CA Construction Administration	Isabella Hamilton	1.00	95.00	95.00 Power plan
6/5/2024	South Walton County Mosquito Control District New Headquarters	Service Order #4 - Admin Bldg Construction Documents, Bidding, CA Construction Administration	Steven Nicholson	3.00	110.00	330.00 Sumbittals and logswork on ASI #001 transom detail
6/6/2024	South Walton County Mosquito Control District New Headquarters	Service Order #4 - Admin Bldg Construction Documents, Bidding, CA Construction Administration	Alex Gacic	4.00	125.00	500.00 Lab equipment follow up
6/6/2024	South Walton County Mosquito Control District New Headquarters	Service Order #4 - Admin Bldg Construction Documents, Bidding, CA Construction Administration	Steven Nicholson	4.00	110.00	440.00 Sumbittals and logslab equipment issues emails back to owner and contractor to resolve and give clarity

6/7/2024	South Walton County Mosquito Control District New Headquarters	Service Order #4 - Admin Bldg Construction Documents, Bidding, CA Construction Administration	Jennifer Langham	1.50	85.00	127.50 furniture outlet location coordination
6/7/2024	South Walton County Mosquito Control District New Headquarters	Service Order #4 - Admin Bldg Construction Documents, Bidding, CA Construction Administration	Steven Nicholson	5.00	110.00	550.00 Submittals and logsASI #001 and revision #8
6/10/2024	South Walton County Mosquito Control District New Headquarters	Service Order #4 - Admin Bldg Construction Documents, Bidding, CA Construction Administration	Alex Gacic	2.00	125.00	250.00 Lab meeting, equipment coordination
6/10/2024	South Walton County Mosquito Control District New Headquarters	Service Order #4 - Admin Bldg Construction Documents, Bidding, CA Construction Administration	Steven Nicholson	3.00	110.00	330.00 work on Rev. 8 itemsreview, send out and return submittals
6/11/2024	South Walton County Mosquito Control District New Headquarters	Service Order #4 - Admin Bldg Construction Documents, Bidding, CA Construction Administration	Alex Gacic	2.00	125.00	250.00 Project meeting and lab coordination
6/11/2024	South Walton County Mosquito Control District New Headquarters	Service Order #4 - Admin Bldg Construction Documents, Bidding, CA Construction Administration	Patrick Ballasch	1.00	275.00	275.00 OAC
6/11/2024	South Walton County Mosquito Control District New Headquarters	Service Order #4 - Admin Bldg Construction Documents, Bidding, CA Construction Administration	Steven Nicholson	4.00	110.00	440.00 OAC Meeting and site walkBridge discussion and possible redesign
6/13/2024	South Walton County Mosquito Control District New Headquarters	Service Order #4 - Admin Bldg Construction Documents, Bidding, CA Construction Administration	Steven Nicholson	3.00	110.00	330.00 work on Rev. 8 add detials for head transom review and return submittalsCivil issue with fish pond not being located in drawings
6/14/2024	South Walton County Mosquito Control District New Headquarters	Service Order #4 - Admin Bldg Construction Documents, Bidding, CA Construction Administration	Steven Nicholson	3.00	110.00	330.00 work on Rev. 8 add detials for head transom review and return submittals
6/17/2024	South Walton County Mosquito Control District New Headquarters	Service Order #4 - Admin Bldg Construction Documents, Bidding, CA Construction Administration	Steven Nicholson	3.00	110.00	330.00 submittals and emailsdoor hardware submittal
6/18/2024	South Walton County Mosquito Control District New Headquarters	Service Order #4 - Admin Bldg Construction Documents, Bidding, CA Construction Administration	Alex Gacic	2.00	125.00	250.00 project meeting
6/18/2024	South Walton County Mosquito Control District New Headquarters	Service Order #4 - Admin Bldg Construction Documents, Bidding, CA Construction Administration	Patrick Ballasch	1.00	275.00	275.00 OAC
6/18/2024	South Walton County Mosquito Control District New Headquarters	Service Order #4 - Admin Bldg Construction Documents, Bidding, CA Construction Administration	Steven Nicholson	3.50	110.00	385.00 OAC Meeting Site walk
6/19/2024	South Walton County Mosquito Control District New Headquarters	Service Order #4 - Admin Bldg Construction Documents, Bidding, CA Construction Administration	Steven Nicholson	3.00	110.00	330.00 submittals lab equipment coordinationrevision #9
6/20/2024	South Walton County Mosquito Control District New Headquarters	Service Order #4 - Admin Bldg Construction Documents, Bidding, CA Construction Administration	Steven Nicholson	2.50	110.00	275.00 submittals lab equipment coordination
6/21/2024	South Walton County Mosquito Control District New Headquarters	Service Order #4 - Admin Bldg Construction Documents, Bidding, CA Construction Administration	Steven Nicholson	2.00	110.00	220.00 meeting minutesubmittals
6/24/2024	South Walton County Mosquito Control District New Headquarters	Service Order #4 - Admin Bldg Construction Documents, Bidding, CA Construction Administration	Steven Nicholson	3.00	110.00	330.00 Submittals and emails
6/25/2024	South Walton County Mosquito Control District New Headquarters	Service Order #4 - Admin Bldg Construction Documents, Bidding, CA Construction Administration	Alex Gacic	1.00	125.00	125.00 Project meeting
6/25/2024	South Walton County Mosquito Control District New Headquarters	Service Order #4 - Admin Bldg Construction Documents, Bidding, CA Construction Administration	Jonah Novack	0.50	95.00	47.50 mosquito bridge
6/25/2024	South Walton County Mosquito Control District New Headquarters	Service Order #4 - Admin Bldg Construction Documents, Bidding, CA Construction Administration	Steven Nicholson	3.00	110.00	330.00 OAC meeting RFIs and submittals
6/26/2024	South Walton County Mosquito Control District New Headquarters	Service Order #4 - Admin Bldg Construction Documents, Bidding, CA Construction Administration	Jonah Novack	1.50	95.00	142.50 mosquito control bridge rendering and such
6/26/2024	South Walton County Mosquito Control District New Headquarters	Service Order #4 - Admin Bldg Construction Documents, Bidding, CA Construction Administration	Steven Nicholson	4.00	110.00	440.00 Submittals and emails
6/27/2024	South Walton County Mosquito Control District New Headquarters	Service Order #4 - Admin Bldg Construction Documents, Bidding, CA Construction Administration	Steven Nicholson	2.00	110.00	220.00 Submittals and emails
6/28/2024	South Walton County Mosquito Control District New Headquarters	Service Order #4 - Admin Bldg Construction Documents, Bidding, CA Construction Administration	Jonah Novack	3.00	95.00	285.00 rendering and such
6/28/2024	South Walton County Mosquito Control District New Headquarters	Service Order #4 - Admin Bldg Construction Documents, Bidding, CA Construction Administration	Patrick Ballasch	0.50	275.00	137.50 bridge design
6/28/2024	South Walton County Mosquito Control District New Headquarters	Service Order #4 - Admin Bldg Construction Documents, Bidding, CA Construction Administration	Steven Nicholson	3.00	110.00	330.00 Submittals and emails
7/2/2024	South Walton County Mosquito Control District New Headquarters	Service Order #4 - Admin Bldg Construction Documents, Bidding, CA Construction Administration	Alex Gacic	1.00	125.00	125.00 Project meeting
7/2/2024	South Walton County Mosquito Control District New Headquarters	Service Order #4 - Admin Bldg Construction Documents, Bidding, CA Construction Administration	Steven Nicholson	4.00	110.00	440.00 OAC meeting submittals and RFIs
7/3/2024	South Walton County Mosquito Control District New Headquarters	Service Order #4 - Admin Bldg Construction Documents, Bidding, CA Construction Administration	Steven Nicholson	3.00	110.00	330.00 submittals and RFIs
7/3/2024	South Walton County Mosquito Control District New Headquarters	Service Order #4 - Admin Bldg Construction Documents, Bidding, CA Construction Administration	Patrick Ballasch	1.00	275.00	275.00 site walk
7/5/2024	South Walton County Mosquito Control District New Headquarters	Service Order #4 - Admin Bldg Construction Documents, Bidding, CA Construction Administration	Steven Nicholson	3.00	110.00	330.00 submittals out to engineersreview area glass storefront elevationsend out rfi to mechanical

7/8/2024	South Walton County Mosquito Control District New Headquarters	Service Order #4 - Admin Bldg Construction Documents, Bidding, CA Construction Administration	Steven Nicholson	3.00	110.00	330.00 Submittals and RFIsbridge design
7/9/2024	South Walton County Mosquito Control District New Headquarters	Service Order #4 - Admin Bldg Construction Documents, Bidding, CA Construction Administration	Alex Gacic	1.00	125.00	125.00 Project Meeting
7/9/2024	South Walton County Mosquito Control District New Headquarters	Service Order #4 - Admin Bldg Construction Documents, Bidding, CA Construction Administration	Steven Nicholson	3.50	110.00	385.00 Submittals and RFIsOAC meeting
7/9/2024	South Walton County Mosquito Control District New Headquarters	Service Order #4 - Admin Bldg Construction Documents, Bidding, CA Construction Administration	Patrick Ballasch	1.00	275.00	275.00 oac
7/10/2024	South Walton County Mosquito Control District New Headquarters	Service Order #4 - Admin Bldg Construction Documents, Bidding, CA Construction Administration	Jennifer Langham	0.50	85.00	42.50 exterior wood stain selection
7/10/2024	South Walton County Mosquito Control District New Headquarters	Service Order #4 - Admin Bldg Construction Documents, Bidding, CA Construction Administration	Steven Nicholson	3.00	110.00	330.00 Submittals and RFIsupdate drawings
7/11/2024	South Walton County Mosquito Control District New Headquarters	Service Order #4 - Admin Bldg Construction Documents, Bidding, CA Construction Administration	Steven Nicholson	4.50	110.00	495.00 submittals and RFIswent to board meeting to get design proposal approved
7/12/2024	South Walton County Mosquito Control District New Headquarters	Service Order #4 - Admin Bldg Construction Documents, Bidding, CA Construction Administration	Steven Nicholson	3.50	110.00	385.00 Submittals and RFIs
7/12/2024	South Walton County Mosquito Control District New Headquarters	Service Order #4 - Admin Bldg Construction Documents, Bidding, CA Construction Administration	Patrick Ballasch	0.50	275.00	137.50 comms
7/15/2024	South Walton County Mosquito Control District New Headquarters	Service Order #4 - Admin Bldg Construction Documents, Bidding, CA Construction Administration	Aidan Berry	3.50	85.00	297.50 Exterior Materials Package.
7/15/2024	South Walton County Mosquito Control District New Headquarters	Service Order #4 - Admin Bldg Construction Documents, Bidding, CA Construction Administration	Steven Nicholson	1.00	110.00	110.00 Review submittals
7/16/2024	South Walton County Mosquito Control District New Headquarters	Service Order #4 - Admin Bldg Construction Documents, Bidding, CA Construction Administration	Patrick Ballasch	1.00	275.00	275.00 OAC
7/16/2024	South Walton County Mosquito Control District New Headquarters	Service Order #4 - Admin Bldg Construction Documents, Bidding, CA Construction Administration	Alex Gacic	1.00	125.00	125.00 Project meeting
7/16/2024	South Walton County Mosquito Control District New Headquarters	Service Order #4 - Admin Bldg Construction Documents, Bidding, CA Construction Administration	Aidan Berry	7.50	85.00	637.50 Exterior Materials Package.
7/16/2024	South Walton County Mosquito Control District New Headquarters	Service Order #4 - Admin Bldg Construction Documents, Bidding, CA Construction Administration	Steven Nicholson	3.00	110.00	330.00 OAC meeting and site visit
7/16/2024	South Walton County Mosquito Control District New Headquarters	Service Order #4 - Admin Bldg Construction Documents, Bidding, CA Construction Administration	Steven Nicholson	1.00	110.00	110.00 Review Submittals
7/17/2024	South Walton County Mosquito Control District New Headquarters	Service Order #4 - Admin Bldg Construction Documents, Bidding, CA Construction Administration	Aidan Berry	4.00	85.00	340.00 Exterior Materials Package.
7/17/2024	South Walton County Mosquito Control District New Headquarters	Service Order #4 - Admin Bldg Construction Documents, Bidding, CA Construction Administration	Steven Nicholson	3.00	110.00	330.00 Review Submittals update log
7/18/2024	South Walton County Mosquito Control District New Headquarters	Service Order #4 - Admin Bldg Construction Documents, Bidding, CA Construction Administration	Alex Gacic	3.00	125.00	375.00 Phase II meeting and coordination
7/18/2024	South Walton County Mosquito Control District New Headquarters	Service Order #4 - Admin Bldg Construction Documents, Bidding, CA Construction Administration	Aidan Berry	2.00	85.00	170.00 Exterior material package.
7/18/2024	South Walton County Mosquito Control District New Headquarters	Service Order #4 - Admin Bldg Construction Documents, Bidding, CA Construction Administration	Steven Nicholson	3.00	110.00	330.00 Review Submittals
7/19/2024	South Walton County Mosquito Control District New Headquarters	Service Order #4 - Admin Bldg Construction Documents, Bidding, CA Construction Administration	Alex Gacic	3.00	125.00	375.00 submittill reviews
7/19/2024	South Walton County Mosquito Control District New Headquarters	Service Order #4 - Admin Bldg Construction Documents, Bidding, CA Construction Administration	Aidan Berry	2.50	85.00	212.50 Exterior materials package.
7/19/2024	South Walton County Mosquito Control District New Headquarters	Service Order #4 - Admin Bldg Construction Documents, Bidding, CA Construction Administration	Steven Nicholson	3.00	110.00	330.00 Review Submittals Revision 12
7/22/2024	South Walton County Mosquito Control District New Headquarters	Service Order #4 - Admin Bldg Construction Documents, Bidding, CA Construction Administration	Alex Gacic	1.00	125.00	125.00 Foward RFI response
7/23/2024	South Walton County Mosquito Control District New Headquarters	Service Order #4 - Admin Bldg Construction Documents, Bidding, CA Construction Administration	Alex Gacic	2.00	125.00	250.00 review rfis
7/23/2024	South Walton County Mosquito Control District New Headquarters	Service Order #4 - Admin Bldg Construction Documents, Bidding, CA Construction Administration	Patrick Ballasch	2.00	275.00	550.00 review pay app
7/25/2024	South Walton County Mosquito Control District New Headquarters	Service Order #4 - Admin Bldg Construction Documents, Bidding, CA Construction Administration	Steven Nicholson	1.00	110.00	110.00 submittals
7/26/2024	South Walton County Mosquito Control District New Headquarters	Service Order #4 - Admin Bldg Construction Documents, Bidding, CA Construction Administration	Steven Nicholson	2.00	110.00	220.00 review submittals and emailsreweiv pay app#4
7/29/2024	South Walton County Mosquito Control District New Headquarters	Service Order #4 - Admin Bldg Construction Documents, Bidding, CA Construction Administration	Alex Gacic	1.00	125.00	125.00 Cement board attachment
7/29/2024	South Walton County Mosquito Control District New Headquarters	Service Order #4 - Admin Bldg Construction Documents, Bidding, CA Construction Administration	Steven Nicholson	2.00	110.00	220.00 Review submittals and answer RFIs

7/30/2024	South Walton County Mosquito Control District New Headquarters	Service Order #4 - Admin Bldg Construction Documents, Bidding, CA Construction Administration	Alex Gacic	1.00	125.00	125.00 Project meeting
7/30/2024	South Walton County Mosquito Control District New Headquarters	Service Order #4 - Admin Bldg Construction Documents, Bidding, CA Construction Administration	Jennifer Langham	1.75	85.00	148.75 lighting submittal meeting with steven
7/30/2024	South Walton County Mosquito Control District New Headquarters	Service Order #4 - Admin Bldg Construction Documents, Bidding, CA Construction Administration	Jennifer Langham	0.75	85.00	63.75 lighting submittal
7/30/2024	South Walton County Mosquito Control District New Headquarters	Service Order #4 - Admin Bldg Construction Documents, Bidding, CA Construction Administration	Steven Nicholson	5.00	110.00	550.00 OAC meeting and site walkreivw lighting submittal and send out for review
7/31/2024	South Walton County Mosquito Control District New Headquarters	Service Order #4 - Admin Bldg Construction Documents, Bidding, CA Construction Administration	Steven Nicholson	2.00	110.00	220.00 submittals
8/1/2024	South Walton County Mosquito Control District New Headquarters	Service Order #4 - Admin Bldg Construction Documents, Bidding, CA Construction Administration	Steven Nicholson	2.00	110.00	220.00 submittals and revision 13
8/2/2024	South Walton County Mosquito Control District New Headquarters	Service Order #4 - Admin Bldg Construction Documents, Bidding, CA Construction Administration	Steven Nicholson	4.00	110.00	440.00 Lighting package submittal bathroom accessories submittal reveiw fire suppression submittal
8/5/2024	South Walton County Mosquito Control District New Headquarters	Service Order #4 - Admin Bldg Construction Documents, Bidding, CA Construction Administration	Alex Gacic	1.00	125.00	125.00 Review observation report and meeting minutes
8/5/2024	South Walton County Mosquito Control District New Headquarters	Service Order #4 - Admin Bldg Construction Documents, Bidding, CA Construction Administration	Steven Nicholson	1.50	110.00	165.00 submittals and answer RFIs
8/6/2024	South Walton County Mosquito Control District New Headquarters	Service Order #4 - Admin Bldg Construction Documents, Bidding, CA Construction Administration	Alex Gacic	1.00	125.00	125.00 Project Meeting
8/6/2024	South Walton County Mosquito Control District New Headquarters	Service Order #4 - Admin Bldg Construction Documents, Bidding, CA Construction Administration	Steven Nicholson	2.00	110.00	220.00 OAC meeting and site visit
8/8/2024	South Walton County Mosquito Control District New Headquarters	Service Order #4 - Admin Bldg Construction Documents, Bidding, CA Construction Administration	Jennifer Langham	1.50	85.00	127.50 client meeting for furniture at Centerline Assoc.
8/8/2024	South Walton County Mosquito Control District New Headquarters	Service Order #4 - Admin Bldg Construction Documents, Bidding, CA Construction Administration	Jennifer Langham	0.75	85.00	63.75 travel to centerline assoc for client meeting
8/8/2024	South Walton County Mosquito Control District New Headquarters	Service Order #4 - Admin Bldg Construction Documents, Bidding, CA Construction Administration	Alex Gacic	2.00	125.00	250.00 Phase 2 meeting
8/8/2024	South Walton County Mosquito Control District New Headquarters	Service Order #4 - Admin Bldg Construction Documents, Bidding, CA Construction Administration	Steven Nicholson	3.00	110.00	330.00 meeting at Centerline for furniture package
8/9/2024	South Walton County Mosquito Control District New Headquarters	Service Order #4 - Admin Bldg Construction Documents, Bidding, CA Construction Administration	Steven Nicholson	2.00	110.00	220.00 review submiitals update submittal logs
8/12/2024	South Walton County Mosquito Control District New Headquarters	Service Order #4 - Admin Bldg Construction Documents, Bidding, CA Construction Administration	Alex Gacic	1.00	125.00	125.00 submittals review
8/12/2024	South Walton County Mosquito Control District New Headquarters	Service Order #4 - Admin Bldg Construction Documents, Bidding, CA Construction Administration	Steven Nicholson	1.50	110.00	165.00 review submittals and RFIs
8/13/2024	South Walton County Mosquito Control District New Headquarters	Service Order #4 - Admin Bldg Construction Documents, Bidding, CA Construction Administration	Alex Gacic	2.00	125.00	250.00 SUBmittals and project meeting
8/13/2024	South Walton County Mosquito Control District New Headquarters	Service Order #4 - Admin Bldg Construction Documents, Bidding, CA Construction Administration	Steven Nicholson	4.50	110.00	495.00 OAC meeting and site visitreview submittals
8/14/2024	South Walton County Mosquito Control District New Headquarters	Service Order #4 - Admin Bldg Construction Documents, Bidding, CA Construction Administration	Steven Nicholson	2.00	110.00	220.00 review submittals and RFIsupdate submittal log
8/15/2024	South Walton County Mosquito Control District New Headquarters	Service Order #4 - Admin Bldg Construction Documents, Bidding, CA Construction Administration	Alex Gacic	2.00	125.00	250.00 REview phase 2 programming requirements and chem storage listing
8/15/2024	South Walton County Mosquito Control District New Headquarters	Service Order #4 - Admin Bldg Construction Documents, Bidding, CA Construction Administration	Steven Nicholson	2.00	110.00	220.00 review submittals and RFIs
8/20/2024	South Walton County Mosquito Control District New Headquarters	Service Order #4 - Admin Bldg Construction Documents, Bidding, CA Construction Administration	Jennifer Langham	0.50	85.00	42.50 casework submittal review
8/20/2024	South Walton County Mosquito Control District New Headquarters	Service Order #4 - Admin Bldg Construction Documents, Bidding, CA Construction Administration	Steven Nicholson	2.00	110.00	220.00 OAC meeting and phase II discussions
8/21/2024	South Walton County Mosquito Control District New Headquarters	Service Order #4 - Admin Bldg Construction Documents, Bidding, CA Construction Administration	Jennifer Langham	3.50	85.00	297.50 casework submittal review
8/21/2024	South Walton County Mosquito Control District New Headquarters	Service Order #4 - Admin Bldg Construction Documents, Bidding, CA Construction Administration	Steven Nicholson	1.50	110.00	165.00 review submittals
8/22/2024	South Walton County Mosquito Control District New Headquarters	Service Order #4 - Admin Bldg Construction Documents, Bidding, CA Construction Administration	Jennifer Langham	0.50	85.00	42.50 CABINET SUBMITTAL
8/22/2024	South Walton County Mosquito Control District New Headquarters	Service Order #4 - Admin Bldg Construction Documents, Bidding, CA Construction Administration	Steven Nicholson	1.00	110.00	110.00 review submittals
8/23/2024	South Walton County Mosquito Control District New Headquarters	Service Order #4 - Admin Bldg Construction Documents, Bidding, CA Construction Administration	Steven Nicholson	2.00	110.00	220.00 review steel doors and frames submittal discuss mech pad with structural
8/26/2024	South Walton County Mosquito Control District New Headquarters	Service Order #4 - Admin Bldg Construction Documents, Bidding, CA Construction Administration	Alex Gacic	2.00	125.00	250.00 Project Coordination

8/27/2024	South Walton County Mosquito Control District New Headquarters	Service Order #4 - Admin Bldg Construction Documents, Bidding, CA Construction Administration	Alex Gacic	1.00	125.00	125.00 Project Meeting
8/27/2024	South Walton County Mosquito Control District New Headquarters	Service Order #4 - Admin Bldg Construction Documents, Bidding, CA Construction Administration	Steven Nicholson	3.00	110.00	330.00 OAC meeting and site visit
8/28/2024	South Walton County Mosquito Control District New Headquarters	Service Order #4 - Admin Bldg Construction Documents, Bidding, CA Construction Administration	Steven Nicholson	1.50	110.00	165.00 review submittals and send back to contractor.
8/30/2024	South Walton County Mosquito Control District New Headquarters	Service Order #4 - Admin Bldg Construction Documents, Bidding, CA Construction Administration	Alex Gacic	2.00	125.00	250.00 billing issue
8/30/2024	South Walton County Mosquito Control District New Headquarters	Service Order #4 - Admin Bldg Construction Documents, Bidding, CA Construction Administration	Steven Nicholson	6.00	110.00	660.00 create site wall detailrevision 13 show enlarged ramp plan/section and detail2hr meeting on Teams with truss manufacturer
9/3/2024	South Walton County Mosquito Control District New Headquarters	Service Order #4 - Admin Bldg Construction Documents, Bidding, CA Construction Administration	Jennifer Langham	1.00	85.00	85.00 furniture coordination
9/3/2024	South Walton County Mosquito Control District New Headquarters	Service Order #4 - Admin Bldg Construction Documents, Bidding, CA Construction Administration	Alex Gacic	1.00	125.00	125.00 Team Meeting
9/3/2024	South Walton County Mosquito Control District New Headquarters	Service Order #4 - Admin Bldg Construction Documents, Bidding, CA Construction Administration	Steven Nicholson	2.00	110.00	220.00 submittals OAC meeting truss designs
9/4/2024	South Walton County Mosquito Control District New Headquarters	Service Order #4 - Admin Bldg Construction Documents, Bidding, CA Construction Administration	Steven Nicholson	3.00	110.00	330.00 truss designupdate roof overhangsanswer RFIs submittals
9/5/2024	South Walton County Mosquito Control District New Headquarters	Service Order #4 - Admin Bldg Construction Documents, Bidding, CA Construction Administration	Jennifer Langham	1.00	85.00	85.00 furniture coordination
9/5/2024	South Walton County Mosquito Control District New Headquarters	Service Order #4 - Admin Bldg Construction Documents, Bidding, CA Construction Administration	Steven Nicholson	3.50	110.00	385.00 meeting to finalize truss designupdate architectural sections to reflect get structural to update details for truss bearingget out revision 13 and supplemental details
9/6/2024	South Walton County Mosquito Control District New Headquarters	Service Order #4 - Admin Bldg Construction Documents, Bidding, CA Construction Administration	Steven Nicholson	4.00	110.00	440.00 update roof overhangsreiew and send out submittals send out approved truss shopsrevision 14
9/13/2024	South Walton County Mosquito Control District New Headquarters	Service Order #4 - Admin Bldg Construction Documents, Bidding, CA Construction Administration	Steven Nicholson	1.00	110.00	110.00 reveiw submittals and answer RFIs
9/16/2024	South Walton County Mosquito Control District New Headquarters	Service Order #4 - Admin Bldg Construction Documents, Bidding, CA Construction Administration	Steven Nicholson	3.00	110.00	330.00 ramp/planter detail
9/17/2024	South Walton County Mosquito Control District New Headquarters	Service Order #4 - Admin Bldg Construction Documents, Bidding, CA Construction Administration	Steven Nicholson	3.50	110.00	385.00 site visit OAC meeting
9/18/2024	South Walton County Mosquito Control District New Headquarters	Service Order #4 - Admin Bldg Construction Documents, Bidding, CA Construction Administration	Steven Nicholson	2.00	110.00	220.00 detail for planter wall allong front stairs
9/19/2024	South Walton County Mosquito Control District New Headquarters	Service Order #4 - Admin Bldg Construction Documents, Bidding, CA Construction Administration	Jennifer Langham	2.00	85.00	170.00 furniture meeting with client
9/19/2024	South Walton County Mosquito Control District New Headquarters	Service Order #4 - Admin Bldg Construction Documents, Bidding, CA Construction Administration	Jennifer Langham	1.00	85.00	85.00 travel to furniture meeting and back
9/19/2024	South Walton County Mosquito Control District New Headquarters	Service Order #4 - Admin Bldg Construction Documents, Bidding, CA Construction Administration	Steven Nicholson	4.00	110.00	440.00 submittals and rfismeeeting at centerline for final furniture package
9/23/2024	South Walton County Mosquito Control District New Headquarters	Service Order #4 - Admin Bldg Construction Documents, Bidding, CA Construction Administration	Jennifer Langham	1.00	85.00	85.00 carpet coordination
9/23/2024	South Walton County Mosquito Control District New Headquarters	Service Order #4 - Admin Bldg Construction Documents, Bidding, CA Construction Administration	Steven Nicholson	1.50	110.00	165.00 Answer RFIs
9/24/2024	South Walton County Mosquito Control District New Headquarters	Service Order #4 - Admin Bldg Construction Documents, Bidding, CA Construction Administration	Steven Nicholson	3.50	110.00	385.00 OAC meeting and site visitanswer RFIs
9/25/2024	South Walton County Mosquito Control District New Headquarters	Service Order #4 - Admin Bldg Construction Documents, Bidding, CA Construction Administration	Steven Nicholson	1.00	110.00	110.00 submittals and get detial for gable louver and ceiling joists
9/30/2024	South Walton County Mosquito Control District New Headquarters	Service Order #4 - Admin Bldg Construction Documents, Bidding, CA Construction Administration	Steven Nicholson	1.00	110.00	110.00 submittals and emails to hunt down submittals
10/1/2024	South Walton County Mosquito Control District New Headquarters	Service Order #4 - Admin Bldg Construction Documents, Bidding, CA Construction Administration	Alex Gacic	1.00	125.00	125.00 Project meeting
10/1/2024	South Walton County Mosquito Control District New Headquarters	Service Order #4 - Admin Bldg Construction Documents, Bidding, CA Construction Administration	Steven Nicholson	3.00	110.00	330.00 OAC meeting and site visit
10/2/2024	South Walton County Mosquito Control District New Headquarters	Service Order #4 - Admin Bldg Construction Documents, Bidding, CA Construction Administration	Steven Nicholson	4.00	110.00	440.00 submittals and RFIsimprontu meeting with AGEIS for railing Questions
10/3/2024	South Walton County Mosquito Control District New Headquarters	Service Order #4 - Admin Bldg Construction Documents, Bidding, CA Construction Administration	Steven Nicholson	2.00	110.00	220.00 Revision 15 railing designs
10/4/2024	South Walton County Mosquito Control District New Headquarters	Service Order #4 - Admin Bldg Construction Documents, Bidding, CA Construction Administration	Steven Nicholson	3.00	110.00	330.00 Revision 15 Railing Designs
10/7/2024	South Walton County Mosquito Control District New Headquarters	Service Order #4 - Admin Bldg Construction Documents, Bidding, CA Construction Administration	Steven Nicholson	3.00	110.00	330.00 meeting with masonry sub and storefront subsite walk
10/7/2024	South Walton County Mosquito Control District New Headquarters	Service Order #4 - Admin Bldg Construction Documents, Bidding, CA Construction Administration	Tara Blake	0.50	90.00	45.00 prepare and Change order for Steven N review

10/8/2024	South Walton County Mosquito Control District New Headquarters	Service Order #4 - Admin Bldg Construction Documents, Bidding, CA Construction Administration	Steven Nicholson	3.00	110.00	330.00 OAC meeting and site walk
10/8/2024	South Walton County Mosquito Control District New Headquarters	Service Order #4 - Admin Bldg Construction Documents, Bidding, CA Construction Administration	Patrick Ballasch	1.00	275.00	275.00 OAC
10/8/2024	South Walton County Mosquito Control District New Headquarters	Service Order #4 - Admin Bldg Construction Documents, Bidding, CA Construction Administration	Tara Blake	0.50	90.00	45.00 Complete & Finalize change order
10/8/2024	South Walton County Mosquito Control District New Headquarters	Service Order #4 - Admin Bldg Construction Documents, Bidding, CA Construction Administration	Alex Gacic	1.50	125.00	187.50 meeting
10/9/2024	South Walton County Mosquito Control District New Headquarters	Service Order #4 - Admin Bldg Construction Documents, Bidding, CA Construction Administration	Patrick Ballasch	0.50	275.00	137.50 review details w steven
10/10/2024	South Walton County Mosquito Control District New Headquarters	Service Order #4 - Admin Bldg Construction Documents, Bidding, CA Construction Administration	Steven Nicholson	2.00	110.00	220.00 submittals and Emails
10/10/2024	South Walton County Mosquito Control District New Headquarters	Service Order #4 - Admin Bldg Construction Documents, Bidding, CA Construction Administration	Patrick Ballasch	0.50	275.00	137.50 review railing mockups
10/10/2024	South Walton County Mosquito Control District New Headquarters	Service Order #4 - Admin Bldg Construction Documents, Bidding, CA Construction Administration	Jennifer Langham	0.15	85.00	12.75 travel
10/10/2024	South Walton County Mosquito Control District New Headquarters	Service Order #4 - Admin Bldg Construction Documents, Bidding, CA Construction Administration	Alex Gacic	1.00	125.00	125.00 Phase 2 coordination meeting
10/11/2024	South Walton County Mosquito Control District New Headquarters	Service Order #4 - Admin Bldg Construction Documents, Bidding, CA Construction Administration	Steven Nicholson	2.00	110.00	220.00 submittals and RFIs
10/14/2024	South Walton County Mosquito Control District New Headquarters	Service Order #4 - Admin Bldg Construction Documents, Bidding, CA Construction Administration	Jennifer Langham	2.00	85.00	170.00 reviewing new furniture package and redlining for furniture dealer
10/14/2024	South Walton County Mosquito Control District New Headquarters	Service Order #4 - Admin Bldg Construction Documents, Bidding, CA Construction Administration	Steven Nicholson	4.00	110.00	440.00 submittals and Rfisstart revision 16 - show bulk head and T&G under rafters
10/15/2024	South Walton County Mosquito Control District New Headquarters	Service Order #4 - Admin Bldg Construction Documents, Bidding, CA Construction Administration	Tara Blake	0.50	90.00	45.00 Revise and finalize CO#2
10/15/2024	South Walton County Mosquito Control District New Headquarters	Service Order #4 - Admin Bldg Construction Documents, Bidding, CA Construction Administration	Alex Gacic	1.00	125.00	125.00 Project Meeting
10/15/2024	South Walton County Mosquito Control District New Headquarters	Service Order #4 - Admin Bldg Construction Documents, Bidding, CA Construction Administration	Steven Nicholson	4.50	110.00	495.00 OAC meeting and submittalsfinish revision 16 - show bulk head and T&G under rafters
10/15/2024	South Walton County Mosquito Control District New Headquarters	Service Order #4 - Admin Bldg Construction Documents, Bidding, CA Construction Administration	Patrick Ballasch	1.00	275.00	275.00 oac
10/16/2024	South Walton County Mosquito Control District New Headquarters	Service Order #4 - Admin Bldg Construction Documents, Bidding, CA Construction Administration	Steven Nicholson	1.50	110.00	165.00 submittals and Rfis
10/17/2024	South Walton County Mosquito Control District New Headquarters	Service Order #4 - Admin Bldg Construction Documents, Bidding, CA Construction Administration	Jennifer Langham	0.50	85.00	42.50 furniture coordination with Centerline Associates
10/17/2024	South Walton County Mosquito Control District New Headquarters	Service Order #4 - Admin Bldg Construction Documents, Bidding, CA Construction Administration	Steven Nicholson	1.50	110.00	165.00 submittals and Rfis
10/18/2024	South Walton County Mosquito Control District New Headquarters	Service Order #4 - Admin Bldg Construction Documents, Bidding, CA Construction Administration	Steven Nicholson	1.50	110.00	165.00 review and send off submittals
10/21/2024	South Walton County Mosquito Control District New Headquarters	Service Order #4 - Admin Bldg Construction Documents, Bidding, CA Construction Administration	Jennifer Langham	2.50	85.00	212.50 furniture coordinationfurniture review
10/22/2024	South Walton County Mosquito Control District New Headquarters	Service Order #4 - Admin Bldg Construction Documents, Bidding, CA Construction Administration	Steven Nicholson	5.50	110.00	605.00 OAC and site visitsubmittals and answer RFIs
10/25/2024	South Walton County Mosquito Control District New Headquarters	Service Order #4 - Admin Bldg Construction Documents, Bidding, CA Construction Administration	Steven Nicholson	3.50	110.00	385.00 ASI #5 Gable louver detail and sections
10/28/2024	South Walton County Mosquito Control District New Headquarters	Service Order #4 - Admin Bldg Construction Documents, Bidding, CA Construction Administration	Steven Nicholson	2.00	110.00	220.00 reveiw submittals coordinate RFIs for domestic water route and exhaust fan on roof
10/29/2024	South Walton County Mosquito Control District New Headquarters	Service Order #4 - Admin Bldg Construction Documents, Bidding, CA Construction Administration	Steven Nicholson	3.50	110.00	385.00 OAC meeting and site visit
10/29/2024	South Walton County Mosquito Control District New Headquarters	Service Order #4 - Admin Bldg Construction Documents, Bidding, CA Construction Administration	Patrick Ballasch	1.00	275.00	275.00 OAC
10/31/2024	South Walton County Mosquito Control District New Headquarters	Service Order #4 - Admin Bldg Construction Documents, Bidding, CA Construction Administration	Steven Nicholson	2.00	110.00	220.00 Review submittals and RFIs
11/1/2024	South Walton County Mosquito Control District New Headquarters	Service Order #4 - Admin Bldg Construction Documents, Bidding, CA Construction Administration	Steven Nicholson	3.00	110.00	330.00 Review toilet partition and roof shop drawings. Answer RFI for roof attachment options
11/4/2024	South Walton County Mosquito Control District New Headquarters	Service Order #4 - Admin Bldg Construction Documents, Bidding, CA Construction Administration	Jennifer Langham	0.75	85.00	63.75 furniture coordination
11/4/2024	South Walton County Mosquito Control District New Headquarters	Service Order #4 - Admin Bldg Construction Documents, Bidding, CA Construction Administration	Steven Nicholson	2.50	110.00	275.00 reverse osmosis system needed to be approved as pex pipe with pvc fittings coordinate with engineer and contractorexhasut fan guy wires and roof tie down
11/5/2024	South Walton County Mosquito Control District New Headquarters	Service Order #4 - Admin Bldg Construction Documents, Bidding, CA Construction Administration	Jennifer Langham	0.50	85.00	42.50 furniture coordination

11/5/2024	South Walton County Mosquito Control District New Headquarters	Service Order #4 - Admin Bldg Construction Documents, Bidding, CA Construction Administration	Steven Nicholson	3.00	110.00	330.00 short OAC meetingfume hood submittal and finishes
11/5/2024	South Walton County Mosquito Control District New Headquarters	Service Order #4 - Admin Bldg Construction Documents, Bidding, CA Construction Administration	Patrick Ballasch	1.00	275.00	275.00 review
11/6/2024	South Walton County Mosquito Control District New Headquarters	Service Order #4 - Admin Bldg Construction Documents, Bidding, CA Construction Administration	Jennifer Langham	1.00	85.00	85.00 casework submittal
11/7/2024	South Walton County Mosquito Control District New Headquarters	Service Order #4 - Admin Bldg Construction Documents, Bidding, CA Construction Administration	Jennifer Langham	3.00	85.00	255.00 furniture coordination
11/8/2024	South Walton County Mosquito Control District New Headquarters	Service Order #4 - Admin Bldg Construction Documents, Bidding, CA Construction Administration	Jennifer Langham	2.00	85.00	170.00 furniture coordination
11/8/2024	South Walton County Mosquito Control District New Headquarters	Service Order #4 - Admin Bldg Construction Documents, Bidding, CA Construction Administration	Steven Nicholson	2.00	110.00	220.00 Review submittalssubmittal log update
11/11/2024	South Walton County Mosquito Control District New Headquarters	Service Order #4 - Admin Bldg Construction Documents, Bidding, CA Construction Administration	Jennifer Langham	1.00	85.00	85.00 furniture coordination
11/11/2024	South Walton County Mosquito Control District New Headquarters	Service Order #4 - Admin Bldg Construction Documents, Bidding, CA Construction Administration	Steven Nicholson	2.50	110.00	275.00 submittals and furniture coordination
11/12/2024	South Walton County Mosquito Control District New Headquarters	Service Order #4 - Admin Bldg Construction Documents, Bidding, CA Construction Administration	Jennifer Langham	1.50	85.00	127.50 furniture coordination
11/12/2024	South Walton County Mosquito Control District New Headquarters	Service Order #4 - Admin Bldg Construction Documents, Bidding, CA Construction Administration	Steven Nicholson	3.00	110.00	330.00 Revision 17 - Bridge railingselect timber tech colors for review
11/12/2024	South Walton County Mosquito Control District New Headquarters	Service Order #4 - Admin Bldg Construction Documents, Bidding, CA Construction Administration	Patrick Ballasch	1.00	275.00	275.00 OAC
11/13/2024	South Walton County Mosquito Control District New Headquarters	Service Order #4 - Admin Bldg Construction Documents, Bidding, CA Construction Administration	Jennifer Langham	1.00	85.00	85.00 toilet partition submittal review
11/13/2024	South Walton County Mosquito Control District New Headquarters	Service Order #4 - Admin Bldg Construction Documents, Bidding, CA Construction Administration	Brookelyn Bolin	0.25	110.00	27.50 partition spec for Jennie
11/13/2024	South Walton County Mosquito Control District New Headquarters	Service Order #4 - Admin Bldg Construction Documents, Bidding, CA Construction Administration	Steven Nicholson	1.50	110.00	165.00 Review Pay application update combined architectural sethunt down AV equipment package and rough-in drawings
11/14/2024	South Walton County Mosquito Control District New Headquarters	Service Order #4 - Admin Bldg Construction Documents, Bidding, CA Construction Administration	Jennifer Langham	0.50	85.00	42.50 furniture coordination
11/14/2024	South Walton County Mosquito Control District New Headquarters	Service Order #4 - Admin Bldg Construction Documents, Bidding, CA Construction Administration	Steven Nicholson	2.50	110.00	275.00 Revision 18 - add timber tech to all railing notes. update all sheets
11/15/2024	South Walton County Mosquito Control District New Headquarters	Service Order #4 - Admin Bldg Construction Documents, Bidding, CA Construction Administration	Steven Nicholson	2.00	110.00	220.00 Revison 18 - timber tech notes and update all drawings necessary plot and combine into latest architectural
11/18/2024	South Walton County Mosquito Control District New Headquarters	Service Order #4 - Admin Bldg Construction Documents, Bidding, CA Construction Administration	Jennifer Langham	0.50	95.00	47.50 FURNITURE COORDINATION
11/19/2024	South Walton County Mosquito Control District New Headquarters	Service Order #4 - Admin Bldg Construction Documents, Bidding, CA Construction Administration	Steven Nicholson	2.00	110.00	220.00 answer RFIs and field calls
11/19/2024	South Walton County Mosquito Control District New Headquarters	Service Order #4 - Admin Bldg Construction Documents, Bidding, CA Construction Administration	Patrick Ballasch	1.00	275.00	275.00 oac
11/21/2024	South Walton County Mosquito Control District New Headquarters	Service Order #4 - Admin Bldg Construction Documents, Bidding, CA Construction Administration	Steven Nicholson	2.00	110.00	220.00 redistribute Revision 18 and updated combined set. Coordinate RFI for AV systems and cabeling required
11/25/2024	South Walton County Mosquito Control District New Headquarters	Service Order #4 - Admin Bldg Construction Documents, Bidding, CA Construction Administration	Steven Nicholson	3.00	110.00	330.00 Emergency site visit regarding framing and electrical locations
11/26/2024	South Walton County Mosquito Control District New Headquarters	Service Order #4 - Admin Bldg Construction Documents, Bidding, CA Construction Administration	Steven Nicholson	1.00	110.00	110.00 Answer RFIs and communications with Contractor/ Consultants
11/26/2024	South Walton County Mosquito Control District New Headquarters	Service Order #4 - Admin Bldg Construction Documents, Bidding, CA Construction Administration	Patrick Ballasch	1.00	275.00	275.00 review
12/2/2024	South Walton County Mosquito Control District New Headquarters	Service Order #4 - Admin Bldg Construction Documents, Bidding, CA Construction Administration	Steven Nicholson	2.50	110.00	275.00 site visit with structural engineer
12/3/2024	South Walton County Mosquito Control District New Headquarters	Service Order #4 - Admin Bldg Construction Documents, Bidding, CA Construction Administration	Steven Nicholson	3.00	110.00	330.00 OAC meeting and site visit
12/4/2024	South Walton County Mosquito Control District New Headquarters	Service Order #4 - Admin Bldg Construction Documents, Bidding, CA Construction Administration	Steven Nicholson	2.00	110.00	220.00 ASI #7 Front porch section and detail
12/5/2024	South Walton County Mosquito Control District New Headquarters	Service Order #4 - Admin Bldg Construction Documents, Bidding, CA Construction Administration	Jennifer Langham	1.00	95.00	95.00 FURNITURE PACKAGE REVIEW
12/6/2024	South Walton County Mosquito Control District New Headquarters	Service Order #4 - Admin Bldg Construction Documents, Bidding, CA Construction Administration	Jennifer Langham	1.50	95.00	142.50 PRE-FURNITURE MEETING AT CENTERLINE
12/6/2024	South Walton County Mosquito Control District New Headquarters	Service Order #4 - Admin Bldg Construction Documents, Bidding, CA Construction Administration	Steven Nicholson	3.00	110.00	330.00 ASI #7 Front porch section and detail
12/9/2024	South Walton County Mosquito Control District New Headquarters	Service Order #4 - Admin Bldg Construction Documents, Bidding, CA Construction Administration	Steven Nicholson	5.00	110.00	550.00 update front porch with cmu planter wall and added columnentry porch roof detail and section

12/10/2024	South Walton County Mosquito Control District New Headquarters	Service Order #4 - Admin Bldg Construction Documents, Bidding, CA Construction Administration	Steven Nicholson	3.00	110.00	330.00 OAC meeting and site visitdiscuss cmu split face change on north wall
12/10/2024	South Walton County Mosquito Control District New Headquarters	Service Order #4 - Admin Bldg Construction Documents, Bidding, CA Construction Administration	Patrick Ballasch	1.00	275.00	275.00 OAC
12/11/2024	South Walton County Mosquito Control District New Headquarters	Service Order #4 - Admin Bldg Construction Documents, Bidding, CA Construction Administration	Steven Nicholson	2.00	110.00	220.00 create demo plan and show control joint locations for entry canopy slab
12/12/2024	South Walton County Mosquito Control District New Headquarters	Service Order #4 - Admin Bldg Construction Documents, Bidding, CA Construction Administration	Steven Nicholson	1.50	110.00	165.00 update north wall section detail for spit face and capstone
12/12/2024	South Walton County Mosquito Control District New Headquarters	Service Order #4 - Admin Bldg Construction Documents, Bidding, CA Construction Administration	Patrick Ballasch	1.00	275.00	275.00 review stairs, handrails
12/16/2024	South Walton County Mosquito Control District New Headquarters	Service Order #4 - Admin Bldg Construction Documents, Bidding, CA Construction Administration	Jennifer Langham	1.50	95.00	142.50 furniture coordination
12/16/2024	South Walton County Mosquito Control District New Headquarters	Service Order #4 - Admin Bldg Construction Documents, Bidding, CA Construction Administration	Steven Nicholson	2.50	110.00	275.00 ASI #7 & 9 drawings
12/17/2024	South Walton County Mosquito Control District New Headquarters	Service Order #4 - Admin Bldg Construction Documents, Bidding, CA Construction Administration	Steven Nicholson	2.00	110.00	220.00 ASI #7 & 9 drawings send out to contractor
12/17/2024	South Walton County Mosquito Control District New Headquarters	Service Order #4 - Admin Bldg Construction Documents, Bidding, CA Construction Administration	Patrick Ballasch	1.00	275.00	275.00 OAC
12/18/2024	South Walton County Mosquito Control District New Headquarters	Service Order #4 - Admin Bldg Construction Documents, Bidding, CA Construction Administration	Steven Nicholson	2.00	110.00	220.00 review TCR and TARs get signed and sent back to contractor
12/19/2024	South Walton County Mosquito Control District New Headquarters	Service Order #4 - Admin Bldg Construction Documents, Bidding, CA Construction Administration	Steven Nicholson	1.50	110.00	165.00 review ODP docs
12/20/2024	South Walton County Mosquito Control District New Headquarters	Service Order #4 - Admin Bldg Construction Documents, Bidding, CA Construction Administration	Steven Nicholson	1.50	110.00	165.00 review odp doc and give to pat
12/20/2024	South Walton County Mosquito Control District New Headquarters	Service Order #4 - Admin Bldg Construction Documents, Bidding, CA Construction Administration	Patrick Ballasch	1.00	275.00	275.00 review
1/2/2025	South Walton County Mosquito Control District New Headquarters	Service Order #4 - Admin Bldg Construction Documents, Bidding, CA Construction Administration	William Rivera	6.75	110.00	742.50 details
1/7/2025	South Walton County Mosquito Control District New Headquarters	Service Order #4 - Admin Bldg Construction Documents, Bidding, CA Construction Administration	Steven Nicholson	3.00	110.00	330.00 OAC meeting and site walk
1/3/2025	South Walton County Mosquito Control District New Headquarters	Service Order #4 - Admin Bldg Construction Documents, Bidding, CA Construction Administration	William Rivera	6.00	110.00	660.00 details ASI#10
1/8/2025	South Walton County Mosquito Control District New Headquarters	Service Order #4 - Admin Bldg Construction Documents, Bidding, CA Construction Administration	Steven Nicholson	2.00	110.00	220.00 Review submittals and send backanswer RFIs
1/6/2025	South Walton County Mosquito Control District New Headquarters	Service Order #4 - Admin Bldg Construction Documents, Bidding, CA Construction Administration	Jennifer Langham	1.00	95.00	95.00 furniture coordination with Centerline Assoc.
1/6/2025	South Walton County Mosquito Control District New Headquarters	Service Order #4 - Admin Bldg Construction Documents, Bidding, CA Construction Administration	William Rivera	0.50	110.00	55.00 picking up redlines
1/6/2025	South Walton County Mosquito Control District New Headquarters	Service Order #4 - Admin Bldg Construction Documents, Bidding, CA Construction Administration	Aidan Berry	2.50	95.00	237.50 Annotating materials on elevations.
1/9/2025	South Walton County Mosquito Control District New Headquarters	Service Order #4 - Admin Bldg Construction Documents, Bidding, CA Construction Administration	Steven Nicholson	2.50	110.00	275.00 Review submittals and send backanswer RFIsSend out ASI #10
1/7/2025	South Walton County Mosquito Control District New Headquarters	Service Order #4 - Admin Bldg Construction Documents, Bidding, CA Construction Administration	Patrick Ballasch	1.00	275.00	275.00 review
1/8/2025	South Walton County Mosquito Control District New Headquarters	Service Order #4 - Admin Bldg Construction Documents, Bidding, CA Construction Administration	Jennifer Langham	1.50	95.00	142.50 furniture coordinationsubmittal
1/10/2025	South Walton County Mosquito Control District New Headquarters	Service Order #4 - Admin Bldg Construction Documents, Bidding, CA Construction Administration	Steven Nicholson	1.50	110.00	165.00 reveiw submittals answer RFI's
1/14/2025	South Walton County Mosquito Control District New Headquarters	Service Order #4 - Admin Bldg Construction Documents, Bidding, CA Construction Administration	Steven Nicholson	2.00	110.00	220.00 review and check Transfer Request and Pay app
1/15/2025	South Walton County Mosquito Control District New Headquarters	Service Order #4 - Admin Bldg Construction Documents, Bidding, CA Construction Administration	Steven Nicholson	2.00	110.00	220.00 Revision 19 coordination
1/10/2025	South Walton County Mosquito Control District New Headquarters	Service Order #4 - Admin Bldg Construction Documents, Bidding, CA Construction Administration	Jennifer Langham	1.00	95.00	95.00 toilet partition resubmittal
1/13/2025	South Walton County Mosquito Control District New Headquarters	Service Order #4 - Admin Bldg Construction Documents, Bidding, CA Construction Administration	Aidan Berry	1.00	95.00	95.00 Elevation material annotations.
1/16/2025	South Walton County Mosquito Control District New Headquarters	Service Order #4 - Admin Bldg Construction Documents, Bidding, CA Construction Administration	Steven Nicholson	3.00	110.00	330.00 site walk with contractor and board of commissioiners
1/14/2025	South Walton County Mosquito Control District New Headquarters	Service Order #4 - Admin Bldg Construction Documents, Bidding, CA Construction Administration	Patrick Ballasch	1.00	275.00	275.00 review, OAC
1/15/2025	South Walton County Mosquito Control District New Headquarters	Service Order #4 - Admin Bldg Construction Documents, Bidding, CA Construction Administration	Jennifer Langham	1.00	95.00	95.00 flooring submittal

1/15/2025	South Walton County Mosquito Control District New Headquarters	Service Order #4 - Admin Bldg Construction Documents, Bidding, CA Construction Administration	Aidan Berry	0.50	95.00	47.50 Section revision.
1/17/2025	South Walton County Mosquito Control District New Headquarters	Service Order #4 - Admin Bldg Construction Documents, Bidding, CA Construction Administration	Steven Nicholson	2.00	110.00	220.00 review submittals
1/16/2025	South Walton County Mosquito Control District New Headquarters	Service Order #4 - Admin Bldg Construction Documents, Bidding, CA Construction Administration	Jennifer Langham	1.00	95.00	95.00 flooring submittal
1/20/2025	South Walton County Mosquito Control District New Headquarters	Service Order #4 - Admin Bldg Construction Documents, Bidding, CA Construction Administration	Steven Nicholson	1.50	110.00	165.00 Submittals and RFIs
1/21/2025	South Walton County Mosquito Control District New Headquarters	Service Order #4 - Admin Bldg Construction Documents, Bidding, CA Construction Administration	Steven Nicholson	2.50	110.00	275.00 Submittals and RFIsOAC meeting
1/23/2025	South Walton County Mosquito Control District New Headquarters	Service Order #4 - Admin Bldg Construction Documents, Bidding, CA Construction Administration	Steven Nicholson	2.00	110.00	220.00 Submittals and RFIs
1/24/2025	South Walton County Mosquito Control District New Headquarters	Service Order #4 - Admin Bldg Construction Documents, Bidding, CA Construction Administration	Steven Nicholson	1.00	110.00	110.00 Submittals and RFIs
1/28/2025	South Walton County Mosquito Control District New Headquarters	Service Order #4 - Admin Bldg Construction Documents, Bidding, CA Construction Administration	Steven Nicholson	3.00	110.00	330.00 Landscape meeting and site walk with landscape sub and owner
1/29/2025	South Walton County Mosquito Control District New Headquarters	Service Order #4 - Admin Bldg Construction Documents, Bidding, CA Construction Administration	Steven Nicholson	1.00	110.00	110.00 review and send out submittals
1/30/2025	South Walton County Mosquito Control District New Headquarters	Service Order #4 - Admin Bldg Construction Documents, Bidding, CA Construction Administration	Steven Nicholson	1.00	110.00	110.00 review and send out submittals
2/3/2025	South Walton County Mosquito Control District New Headquarters	Service Order #4 - Admin Bldg Construction Documents, Bidding, CA Construction Administration	Steven Nicholson	1.00	110.00	110.00 Review submittals and answer field RFIs
2/4/2025	South Walton County Mosquito Control District New Headquarters	Service Order #4 - Admin Bldg Construction Documents, Bidding, CA Construction Administration	Steven Nicholson	4.00	110.00	440.00 OAC meeting and site visit.Found multiple discrepancies in field, working on supplemental drawings
2/5/2025	South Walton County Mosquito Control District New Headquarters	Service Order #4 - Admin Bldg Construction Documents, Bidding, CA Construction Administration	Steven Nicholson	1.00	110.00	110.00 Review submittals
2/4/2025	South Walton County Mosquito Control District New Headquarters	Service Order #4 - Admin Bldg Construction Documents, Bidding, CA Construction Administration	Patrick Ballasch	1.00	275.00	275.00 OAC
2/6/2025	South Walton County Mosquito Control District New Headquarters	Service Order #4 - Admin Bldg Construction Documents, Bidding, CA Construction Administration	Steven Nicholson	2.00	110.00	220.00 Submittals and site visit coordination
2/7/2025	South Walton County Mosquito Control District New Headquarters	Service Order #4 - Admin Bldg Construction Documents, Bidding, CA Construction Administration	Steven Nicholson	1.00	110.00	110.00 submittals and RFIs
2/10/2025	South Walton County Mosquito Control District New Headquarters	Service Order #4 - Admin Bldg Construction Documents, Bidding, CA Construction Administration	Steven Nicholson	3.00	110.00	330.00 Review TCRs and TARsReview Pay App
2/11/2025	South Walton County Mosquito Control District New Headquarters	Service Order #4 - Admin Bldg Construction Documents, Bidding, CA Construction Administration	Steven Nicholson	1.00	110.00	110.00 submittal log and RFIs
2/13/2025	South Walton County Mosquito Control District New Headquarters	Service Order #4 - Admin Bldg Construction Documents, Bidding, CA Construction Administration	Steven Nicholson	2.00	110.00	220.00 submittals and RFIsupdate submittal Log
2/14/2025	South Walton County Mosquito Control District New Headquarters	Service Order #4 - Admin Bldg Construction Documents, Bidding, CA Construction Administration	Steven Nicholson	1.50	110.00	165.00 Submittal log and RFIs
2/12/2025	South Walton County Mosquito Control District New Headquarters	Service Order #4 - Admin Bldg Construction Documents, Bidding, CA Construction Administration	Jennifer Langham	1.00	95.00	95.00 change in paint in drawings and schedule for contractor
2/18/2025	South Walton County Mosquito Control District New Headquarters	Service Order #4 - Admin Bldg Construction Documents, Bidding, CA Construction Administration	Steven Nicholson	3.50	110.00	385.00 OAC meeting Site Inspections check roof for oil canning
2/20/2025	South Walton County Mosquito Control District New Headquarters	Service Order #4 - Admin Bldg Construction Documents, Bidding, CA Construction Administration	Steven Nicholson	3.00	110.00	330.00 Board meetingStart Alys beach boards for connect
2/18/2025	South Walton County Mosquito Control District New Headquarters	Service Order #4 - Admin Bldg Construction Documents, Bidding, CA Construction Administration	Patrick Ballasch	1.00	275.00	275.00 OAC
2/24/2025	South Walton County Mosquito Control District New Headquarters	Service Order #4 - Admin Bldg Construction Documents, Bidding, CA Construction Administration	Steven Nicholson	1.00	110.00	110.00 Answer RFIs
2/25/2025	South Walton County Mosquito Control District New Headquarters	Service Order #4 - Admin Bldg Construction Documents, Bidding, CA Construction Administration	Steven Nicholson	3.00	110.00	330.00 Emergency requested site visit to inspect roofing materials and installation
2/20/2025	South Walton County Mosquito Control District New Headquarters	Service Order #4 - Admin Bldg Construction Documents, Bidding, CA Construction Administration	Jennifer Langham	1.00	95.00	95.00 furniture coordination
2/24/2025	South Walton County Mosquito Control District New Headquarters	Service Order #4 - Admin Bldg Construction Documents, Bidding, CA Construction Administration	Brookelyn Bolin	0.25	110.00	27.50 sharpie on quartz troubleshoot
2/27/2025	South Walton County Mosquito Control District New Headquarters	Service Order #4 - Admin Bldg Construction Documents, Bidding, CA Construction Administration	Steven Nicholson	1.00	110.00	110.00 split face and capstone detail for back porch
3/3/2025	South Walton County Mosquito Control District New Headquarters	Service Order #4 - Admin Bldg Construction Documents, Bidding, CA Construction Administration	Steven Nicholson	1.00	110.00	110.00 RFIs and coordinationStart ASI for capstone
2/25/2025	South Walton County Mosquito Control District New Headquarters	Service Order #4 - Admin Bldg Construction Documents, Bidding, CA Construction Administration	Patrick Ballasch	1.00	275.00	275.00 OAC

3/5/2025	South Walton County Mosquito Control District New Headquarters	Service Order #4 - Admin Bldg Construction Documents, Bidding, CA Construction Administration	Steven Nicholson	1.50	110.00	165.00 Coordinate Landscape update at entry along 393
3/13/2025	South Walton County Mosquito Control District New Headquarters	Service Order #4 - Admin Bldg Construction Documents, Bidding, CA Construction Administration	Steven Nicholson	2.00	110.00	220.00 Meeting with AV engineer and sub
3/17/2025	South Walton County Mosquito Control District New Headquarters	Service Order #4 - Admin Bldg Construction Documents, Bidding, CA Construction Administration	Steven Nicholson	1.00	110.00	110.00 Answer RFIs and submittals
3/18/2025	South Walton County Mosquito Control District New Headquarters	Service Order #4 - Admin Bldg Construction Documents, Bidding, CA Construction Administration	Steven Nicholson	1.50	110.00	165.00 OAC meeting
3/19/2025	South Walton County Mosquito Control District New Headquarters	Service Order #4 - Admin Bldg Construction Documents, Bidding, CA Construction Administration	Steven Nicholson	2.00	110.00	220.00 Answer RFIs and submittals
3/24/2025	South Walton County Mosquito Control District New Headquarters	Service Order #4 - Admin Bldg Construction Documents, Bidding, CA Construction Administration	Steven Nicholson	1.00	110.00	110.00 RFI and answers
3/25/2025	South Walton County Mosquito Control District New Headquarters	Service Order #4 - Admin Bldg Construction Documents, Bidding, CA Construction Administration	Steven Nicholson	1.50	110.00	165.00 OAC meeting
3/24/2025	South Walton County Mosquito Control District New Headquarters	Service Order #4 - Admin Bldg Construction Documents, Bidding, CA Construction Administration	Jennifer Langham	1.00	95.00	95.00 revision 21
3/28/2025	South Walton County Mosquito Control District New Headquarters	Service Order #4 - Admin Bldg Construction Documents, Bidding, CA Construction Administration	Steven Nicholson	1.00	110.00	110.00 Review Capstone submittal
3/31/2025	South Walton County Mosquito Control District New Headquarters	Service Order #4 - Admin Bldg Construction Documents, Bidding, CA Construction Administration	Steven Nicholson	1.50	110.00	165.00 french drain installation issuesdiscuss remedy with Civil
4/1/2025	South Walton County Mosquito Control District New Headquarters	Service Order #4 - Admin Bldg Construction Documents, Bidding, CA Construction Administration	Steven Nicholson	3.00	110.00	330.00 OAC meeting and site visit
4/3/2025	South Walton County Mosquito Control District New Headquarters	Service Order #4 - Admin Bldg Construction Documents, Bidding, CA Construction Administration	Steven Nicholson	1.00	110.00	110.00 fill out field report
4/4/2025	South Walton County Mosquito Control District New Headquarters	Service Order #4 - Admin Bldg Construction Documents, Bidding, CA Construction Administration	Steven Nicholson	2.00	110.00	220.00 Review pay app and TCRs
4/7/2025	South Walton County Mosquito Control District New Headquarters	Service Order #4 - Admin Bldg Construction Documents, Bidding, CA Construction Administration	Steven Nicholson	1.00	110.00	110.00 Submittals and RFIs
4/10/2025	South Walton County Mosquito Control District New Headquarters	Service Order #4 - Admin Bldg Construction Documents, Bidding, CA Construction Administration	Steven Nicholson	1.00	110.00	110.00 Submittals and RFIs
4/11/2025	South Walton County Mosquito Control District New Headquarters	Service Order #4 - Admin Bldg Construction Documents, Bidding, CA Construction Administration	Steven Nicholson	1.00	110.00	110.00 coordinate RFIs & submittals
4/17/2025	South Walton County Mosquito Control District New Headquarters	Service Order #4 - Admin Bldg Construction Documents, Bidding, CA Construction Administration	Steven Nicholson	3.00	110.00	330.00 Site visit to discuss railing design and installation inspect large kdat framing for imperfections.
4/18/2025	South Walton County Mosquito Control District New Headquarters	Service Order #4 - Admin Bldg Construction Documents, Bidding, CA Construction Administration	Steven Nicholson	1.00	110.00	110.00 RFI #34 & #35
4/21/2025	South Walton County Mosquito Control District New Headquarters	Service Order #4 - Admin Bldg Construction Documents, Bidding, CA Construction Administration	Steven Nicholson	2.00	110.00	220.00 Submittals and update log
4/22/2025	South Walton County Mosquito Control District New Headquarters	Service Order #4 - Admin Bldg Construction Documents, Bidding, CA Construction Administration	Steven Nicholson	3.00	110.00	330.00 Site visit to inspect new roofing material
4/23/2025	South Walton County Mosquito Control District New Headquarters	Service Order #4 - Admin Bldg Construction Documents, Bidding, CA Construction Administration	Steven Nicholson	2.50	110.00	275.00 review change orders and revisions that relate
4/28/2025	South Walton County Mosquito Control District New Headquarters	Service Order #4 - Admin Bldg Construction Documents, Bidding, CA Construction Administration	Steven Nicholson	2.00	110.00	220.00 change orders and submittals
4/29/2025	South Walton County Mosquito Control District New Headquarters	Service Order #4 - Admin Bldg Construction Documents, Bidding, CA Construction Administration	Steven Nicholson	4.00	110.00	440.00 OAC meeting & site visit
4/30/2025	South Walton County Mosquito Control District New Headquarters	Service Order #4 - Admin Bldg Construction Documents, Bidding, CA Construction Administration	Steven Nicholson	2.00	110.00	220.00 submittals and coordination
5/2/2025	South Walton County Mosquito Control District New Headquarters	Service Order #4 - Admin Bldg Construction Documents, Bidding, CA Construction Administration	Steven Nicholson	1.50	110.00	165.00 CA phone calls discuss Landscape phasing
5/6/2025	South Walton County Mosquito Control District New Headquarters	Service Order #4 - Admin Bldg Construction Documents, Bidding, CA Construction Administration	Steven Nicholson	2.00	110.00	220.00 coordinate submittals
5/7/2025	South Walton County Mosquito Control District New Headquarters	Service Order #4 - Admin Bldg Construction Documents, Bidding, CA Construction Administration	Steven Nicholson	2.00	110.00	220.00 coordinate submittals
5/8/2025	South Walton County Mosquito Control District New Headquarters	Service Order #4 - Admin Bldg Construction Documents, Bidding, CA Construction Administration	Steven Nicholson	1.00	110.00	110.00 coordinate submittals
5/12/2025	South Walton County Mosquito Control District New Headquarters	Service Order #4 - Admin Bldg Construction Documents, Bidding, CA Construction Administration	Steven Nicholson	2.50	110.00	275.00 Change orders reviewcoordinate CAD files for Civil and contractorReview concrete stair as built
5/13/2025	South Walton County Mosquito Control District New Headquarters	Service Order #4 - Admin Bldg Construction Documents, Bidding, CA Construction Administration	Steven Nicholson	3.00	110.00	330.00 OAC meeting and site walk
5/14/2025	South Walton County Mosquito Control District New Headquarters	Service Order #4 - Admin Bldg Construction Documents, Bidding, CA Construction Administration	Steven Nicholson	1.50	110.00	165.00 review new submittals

5/19/2025	South Walton County Mosquito Control District New Headquarters	Service Order #4 - Admin Bldg Construction Documents, Bidding, CA Construction Administration	Steven Nicholson	1.00	110.00	110.00 Submittals and RFIs
5/20/2025	South Walton County Mosquito Control District New Headquarters	Service Order #4 - Admin Bldg Construction Documents, Bidding, CA Construction Administration	Steven Nicholson	1.50	110.00	165.00 timbertech bridge layout
5/21/2025	South Walton County Mosquito Control District New Headquarters	Service Order #4 - Admin Bldg Construction Documents, Bidding, CA Construction Administration	Steven Nicholson	1.00	110.00	110.00 Submittals and Change order
5/22/2025	South Walton County Mosquito Control District New Headquarters	Service Order #4 - Admin Bldg Construction Documents, Bidding, CA Construction Administration	Steven Nicholson	1.00	110.00	110.00 Submittals and Change orders
5/21/2025	South Walton County Mosquito Control District New Headquarters	Service Order #4 - Admin Bldg Construction Documents, Bidding, CA Construction Administration	Rachael Stewart	0.25	60.00	15.00 G701-2017 ODP Change Order #4
5/27/2025	South Walton County Mosquito Control District New Headquarters	Service Order #4 - Admin Bldg Construction Documents, Bidding, CA Construction Administration	Steven Nicholson	3.50	110.00	385.00 OAC Meeting and site visit
5/22/2025	South Walton County Mosquito Control District New Headquarters	Service Order #4 - Admin Bldg Construction Documents, Bidding, CA Construction Administration	Rachael Stewart	0.25	60.00	15.00 Edited on G701-2017 Change Order
5/28/2025	South Walton County Mosquito Control District New Headquarters	Service Order #4 - Admin Bldg Construction Documents, Bidding, CA Construction Administration	Steven Nicholson	2.00	110.00	220.00 Coordinate lighting and capstone
5/30/2025	South Walton County Mosquito Control District New Headquarters	Service Order #4 - Admin Bldg Construction Documents, Bidding, CA Construction Administration	Steven Nicholson	1.50	110.00	165.00 submittals and RFIs
6/2/2025	South Walton County Mosquito Control District New Headquarters	Service Order #4 - Admin Bldg Construction Documents, Bidding, CA Construction Administration	Steven Nicholson	1.00	110.00	110.00 Review Pay App
6/3/2025	South Walton County Mosquito Control District New Headquarters	Service Order #4 - Admin Bldg Construction Documents, Bidding, CA Construction Administration	Steven Nicholson	3.00	110.00	330.00 site visit and review railing
6/4/2025	South Walton County Mosquito Control District New Headquarters	Service Order #4 - Admin Bldg Construction Documents, Bidding, CA Construction Administration	Steven Nicholson	1.50	110.00	165.00 Review Pay App and change orders
6/6/2025	South Walton County Mosquito Control District New Headquarters	Service Order #4 - Admin Bldg Construction Documents, Bidding, CA Construction Administration	Steven Nicholson	2.00	110.00	220.00 review pay apps and change orders
6/9/2025	South Walton County Mosquito Control District New Headquarters	Service Order #4 - Admin Bldg Construction Documents, Bidding, CA Construction Administration	Steven Nicholson	1.50	110.00	165.00 Answer RFIs
6/10/2025	South Walton County Mosquito Control District New Headquarters	Service Order #4 - Admin Bldg Construction Documents, Bidding, CA Construction Administration	Steven Nicholson	3.50	110.00	385.00 OAC Meeting and site visit
6/13/2025	South Walton County Mosquito Control District New Headquarters	Service Order #4 - Admin Bldg Construction Documents, Bidding, CA Construction Administration	Steven Nicholson	3.00	110.00	330.00 answering RFIsupdate drawings and create ASI 13-15
6/16/2025	South Walton County Mosquito Control District New Headquarters	Service Order #4 - Admin Bldg Construction Documents, Bidding, CA Construction Administration	Steven Nicholson	1.50	110.00	165.00 review pay apps and invoices study lumber package and what was purchased as KDAT but installed as #2 P.T.
6/12/2025	South Walton County Mosquito Control District New Headquarters	Service Order #4 - Admin Bldg Construction Documents, Bidding, CA Construction Administration	Patrick Ballasch	2.50	275.00	687.50 site visit, meet w darren and WS
6/18/2025	South Walton County Mosquito Control District New Headquarters	Service Order #4 - Admin Bldg Construction Documents, Bidding, CA Construction Administration	Steven Nicholson	2.00	110.00	220.00 ASI #16 detail window trim and hardie panels. section of outrigger condition and angle desired
6/19/2025	South Walton County Mosquito Control District New Headquarters	Service Order #4 - Admin Bldg Construction Documents, Bidding, CA Construction Administration	Steven Nicholson	2.50	110.00	275.00 Meeting to discuss feild report with contractor and owner
6/16/2025	South Walton County Mosquito Control District New Headquarters	Service Order #4 - Admin Bldg Construction Documents, Bidding, CA Construction Administration	Patrick Ballasch	1.00	275.00	275.00 review
6/20/2025	South Walton County Mosquito Control District New Headquarters	Service Order #4 - Admin Bldg Construction Documents, Bidding, CA Construction Administration	Steven Nicholson	1.50	110.00	165.00 coordinate ditch railing with contractor
6/23/2025	South Walton County Mosquito Control District New Headquarters	Service Order #4 - Admin Bldg Construction Documents, Bidding, CA Construction Administration	Steven Nicholson	2.00	110.00	220.00 CA coordination with the contractor
6/24/2025	South Walton County Mosquito Control District New Headquarters	Service Order #4 - Admin Bldg Construction Documents, Bidding, CA Construction Administration	Steven Nicholson	2.50	110.00	275.00 Site visit and work through feild changes
6/25/2025	South Walton County Mosquito Control District New Headquarters	Service Order #4 - Admin Bldg Construction Documents, Bidding, CA Construction Administration	Steven Nicholson	1.50	110.00	165.00 add rain chains on north roof by boardroom
6/26/2025	South Walton County Mosquito Control District New Headquarters	Service Order #4 - Admin Bldg Construction Documents, Bidding, CA Construction Administration	Steven Nicholson	1.00	110.00	110.00 add rain chains on north roof by boardroom and by front porch stairs
6/27/2025	South Walton County Mosquito Control District New Headquarters	Service Order #4 - Admin Bldg Construction Documents, Bidding, CA Construction Administration	Steven Nicholson	2.00	110.00	220.00 coordinate new rain chain locations with Civil add planter rain chain pots at each location
6/30/2025	South Walton County Mosquito Control District New Headquarters	Service Order #4 - Admin Bldg Construction Documents, Bidding, CA Construction Administration	Steven Nicholson	3.50	110.00	385.00 coordinate downspout on north elevation create detail for planter pot drain basin for rain chains.
6/26/2025	South Walton County Mosquito Control District New Headquarters	Service Order #4 - Admin Bldg Construction Documents, Bidding, CA Construction Administration	Patrick Ballasch	1.00	275.00	275.00 review w steven
7/1/2025	South Walton County Mosquito Control District New Headquarters	Service Order #4 - Admin Bldg Construction Documents, Bidding, CA Construction Administration	Steven Nicholson	3.00	110.00	330.00 Review irrigation submittalstart looking into rain chain basin detail and how to tie into stormwatermeeting for commisioning
7/2/2025	South Walton County Mosquito Control District New Headquarters	Service Order #4 - Admin Bldg Construction Documents, Bidding, CA Construction Administration	Steven Nicholson	3.00	110.00	330.00 planter pot rain chain detail

7/3/2025	South Walton County Mosquito Control District New Headquarters	Service Order #4 - Admin Bldg Construction Documents, Bidding, CA Construction Administration	Steven Nicholson	1.50	110.00	165.00 Finalize planter pot rain chain details
7/7/2025	South Walton County Mosquito Control District New Headquarters	Service Order #4 - Admin Bldg Construction Documents, Bidding, CA Construction Administration	Steven Nicholson	5.00	110.00	550.00 Travel to Panama City Beach Mosquito with Darrin to research chem hood drainageDrove around shopping for planter pots for the Admin building rain chains
7/8/2025	South Walton County Mosquito Control District New Headquarters	Service Order #4 - Admin Bldg Construction Documents, Bidding, CA Construction Administration	Steven Nicholson	4.00	110.00	440.00 OAC meetingSite walk with the team
7/10/2025	South Walton County Mosquito Control District New Headquarters	Service Order #4 - Admin Bldg Construction Documents, Bidding, CA Construction Administration	Steven Nicholson	1.00	110.00	110.00 coordinate electrical and motor switch for water heater
7/11/2025	South Walton County Mosquito Control District New Headquarters	Service Order #4 - Admin Bldg Construction Documents, Bidding, CA Construction Administration	Steven Nicholson	2.00	110.00	220.00 coordinate downspouts and rain chain spout sizes required.
7/8/2025	South Walton County Mosquito Control District New Headquarters	Service Order #4 - Admin Bldg Construction Documents, Bidding, CA Construction Administration	Patrick Ballasch	0.50	275.00	137.50 review w steven
7/11/2025	South Walton County Mosquito Control District New Headquarters	Service Order #4 - Admin Bldg Construction Documents, Bidding, CA Construction Administration	Steven Nicholson	2.00	110.00	220.00 finalize monument sign coordinate with Aiden for the model
7/14/2025	South Walton County Mosquito Control District New Headquarters	Service Order #4 - Admin Bldg Construction Documents, Bidding, CA Construction Administration	Steven Nicholson	1.50	110.00	165.00 Submittal and review hot ticket items and report back to contractor
7/15/2025	South Walton County Mosquito Control District New Headquarters	Service Order #4 - Admin Bldg Construction Documents, Bidding, CA Construction Administration	Steven Nicholson	1.50	110.00	165.00 update rainchain locations in floor plan, roof plan and coordinate with Civil
7/16/2025	South Walton County Mosquito Control District New Headquarters	Service Order #4 - Admin Bldg Construction Documents, Bidding, CA Construction Administration	Steven Nicholson	1.50	110.00	165.00 Coordinate stormwater revisions with civil
7/14/2025	South Walton County Mosquito Control District New Headquarters	Service Order #4 - Admin Bldg Construction Documents, Bidding, CA Construction Administration	Patrick Ballasch	1.00	275.00	275.00 review w steven
7/17/2025	South Walton County Mosquito Control District New Headquarters	Service Order #4 - Admin Bldg Construction Documents, Bidding, CA Construction Administration	Steven Nicholson	1.00	110.00	110.00 Review Civil Drainage for stormwater/downspout locations
7/22/2025	South Walton County Mosquito Control District New Headquarters	Service Order #4 - Admin Bldg Construction Documents, Bidding, CA Construction Administration	Steven Nicholson	3.00	110.00	330.00 OAC meeting and site visit
7/23/2025	South Walton County Mosquito Control District New Headquarters	Service Order #4 - Admin Bldg Construction Documents, Bidding, CA Construction Administration	Steven Nicholson	2.50	110.00	275.00 Site Visit with Darrin to select planter potsmodel new downspouts on the north elevation to connect to stormwater
7/22/2025	South Walton County Mosquito Control District New Headquarters	Service Order #4 - Admin Bldg Construction Documents, Bidding, CA Construction Administration	Patrick Ballasch	1.00	275.00	275.00 oac
7/24/2025	South Walton County Mosquito Control District New Headquarters	Service Order #4 - Admin Bldg Construction Documents, Bidding, CA Construction Administration	Steven Nicholson	2.50	110.00	275.00 create ASI #18 for downspouts and lambs tongue for the north roof
7/28/2025	South Walton County Mosquito Control District New Headquarters	Service Order #4 - Admin Bldg Construction Documents, Bidding, CA Construction Administration	Steven Nicholson	3.00	110.00	330.00 Punch walk for C.O.
7/29/2025	South Walton County Mosquito Control District New Headquarters	Service Order #4 - Admin Bldg Construction Documents, Bidding, CA Construction Administration	Steven Nicholson	1.00	110.00	110.00 Look into ADA showerr and transfer clearance
7/25/2025	South Walton County Mosquito Control District New Headquarters	Service Order #4 - Admin Bldg Construction Documents, Bidding, CA Construction Administration	Patrick Ballasch	1.00	275.00	275.00 review w steven
7/30/2025	South Walton County Mosquito Control District New Headquarters	Service Order #4 - Admin Bldg Construction Documents, Bidding, CA Construction Administration	Steven Nicholson	2.00	110.00	220.00 Take Aiden (intern) for a site visit
8/1/2025	South Walton County Mosquito Control District New Headquarters	Service Order #4 - Admin Bldg Construction Documents, Bidding, CA Construction Administration	Steven Nicholson	1.00	110.00	110.00 Review Pay app
8/11/2025	South Walton County Mosquito Control District New Headquarters	Service Order #4 - Admin Bldg Construction Documents, Bidding, CA Construction Administration	Steven Nicholson	5.00	110.00	550.00 Punch walk with Owner and contractor
8/14/2025	South Walton County Mosquito Control District New Headquarters	Service Order #4 - Admin Bldg Construction Documents, Bidding, CA Construction Administration	Steven Nicholson	2.00	110.00	220.00 add notes and pictures to punch walk list
8/11/2025	South Walton County Mosquito Control District New Headquarters	Service Order #4 - Admin Bldg Construction Documents, Bidding, CA Construction Administration	Isabella Hamilton	6.00	95.00	570.00 punch walk with SN
8/18/2025	South Walton County Mosquito Control District New Headquarters	Service Order #4 - Admin Bldg Construction Documents, Bidding, CA Construction Administration	Steven Nicholson	1.50	110.00	165.00 ASI details and submittal
8/21/2025	South Walton County Mosquito Control District New Headquarters	Service Order #4 - Admin Bldg Construction Documents, Bidding, CA Construction Administration	Steven Nicholson	1.00	110.00	110.00 Review submittals and send back out
8/26/2025	South Walton County Mosquito Control District New Headquarters	Service Order #4 - Admin Bldg Construction Documents, Bidding, CA Construction Administration	Steven Nicholson	2.00	110.00	220.00 OAC meeting and site walk
8/28/2025	South Walton County Mosquito Control District New Headquarters	Service Order #4 - Admin Bldg Construction Documents, Bidding, CA Construction Administration	Steven Nicholson	1.00	110.00	110.00 Review submittals and send back out
9/2/2025	South Walton County Mosquito Control District New Headquarters	Service Order #4 - Admin Bldg Construction Documents, Bidding, CA Construction Administration	Steven Nicholson	1.50	110.00	165.00 Review submittals for Crestron system
9/3/2025	South Walton County Mosquito Control District New Headquarters	Service Order #4 - Admin Bldg Construction Documents, Bidding, CA Construction Administration	Steven Nicholson	1.00	110.00	110.00 Coordinante with Telecom to revise drawings to show access control and buzzer at lobby door
9/4/2025	South Walton County Mosquito Control District New Headquarters	Service Order #4 - Admin Bldg Construction Documents, Bidding, CA Construction Administration	Steven Nicholson	1.50	110.00	165.00 coordinate Access control for buzzer door in lobby

9/5/2025	South Walton County Mosquito Control District New Headquarters	Service Order #4 - Admin Bldg Construction Documents, Bidding, CA Construction Administration	Steven Nicholson	1.00	110.00	110.00 Review pay app
9/9/2025	South Walton County Mosquito Control District New Headquarters	Service Order #4 - Admin Bldg Construction Documents, Bidding, CA Construction Administration	Steven Nicholson	3.00	110.00	330.00 OAC and Site meeting
9/11/2025	South Walton County Mosquito Control District New Headquarters	Service Order #4 - Admin Bldg Construction Documents, Bidding, CA Construction Administration	Steven Nicholson	1.50	110.00	165.00 Design vertical french drain ASI #19
9/12/2025	South Walton County Mosquito Control District New Headquarters	Service Order #4 - Admin Bldg Construction Documents, Bidding, CA Construction Administration	Steven Nicholson	1.00	110.00	110.00 Edit ASI #19 add geo fabric to the detail
9/15/2025	South Walton County Mosquito Control District New Headquarters	Service Order #4 - Admin Bldg Construction Documents, Bidding, CA Construction Administration	Steven Nicholson	1.50	110.00	165.00 discussion and planning on what to do with the parking space that has a light pole partially in it.
9/16/2025	South Walton County Mosquito Control District New Headquarters	Service Order #4 - Admin Bldg Construction Documents, Bidding, CA Construction Administration	Steven Nicholson	1.50	110.00	165.00 Review feild reports and send back to the contractor.
9/23/2025	South Walton County Mosquito Control District New Headquarters	Service Order #4 - Admin Bldg Construction Documents, Bidding, CA Construction Administration	Steven Nicholson	2.00	110.00	220.00 Site visit inspectionsdiscuss downspout storm water tie-insreview punch list
9/25/2025	South Walton County Mosquito Control District New Headquarters	Service Order #4 - Admin Bldg Construction Documents, Bidding, CA Construction Administration	Steven Nicholson	1.00	110.00	110.00 Discussions regarding downspouts on the north side and how to tie into stormwater
9/26/2025	South Walton County Mosquito Control District New Headquarters	Service Order #4 - Admin Bldg Construction Documents, Bidding, CA Construction Administration	Steven Nicholson	1.00	110.00	110.00 Review Pay App #18
9/29/2025	South Walton County Mosquito Control District New Headquarters	Service Order #4 - Admin Bldg Construction Documents, Bidding, CA Construction Administration	Steven Nicholson	1.50	110.00	165.00 Answer RFIs
10/8/2025	South Walton County Mosquito Control District New Headquarters	Service Order #4 - Admin Bldg Construction Documents, Bidding, CA Construction Administration	Steven Nicholson	2.00	110.00	220.00 RFIs review for water supply line and parking space
10/13/2025	South Walton County Mosquito Control District New Headquarters	Service Order #4 - Admin Bldg Construction Documents, Bidding, CA Construction Administration	Steven Nicholson	0.50	110.00	55.00 Review observation report from last weeks walk
10/14/2025	South Walton County Mosquito Control District New Headquarters	Service Order #4 - Admin Bldg Construction Documents, Bidding, CA Construction Administration	Steven Nicholson	0.50	110.00	55.00 Phone call to discuss electrical remedy
10/15/2025	South Walton County Mosquito Control District New Headquarters	Service Order #4 - Admin Bldg Construction Documents, Bidding, CA Construction Administration	Steven Nicholson	3.00	110.00	330.00 Owner called punch list with HG and Contractors
10/16/2025	South Walton County Mosquito Control District New Headquarters	Service Order #4 - Admin Bldg Construction Documents, Bidding, CA Construction Administration	Steven Nicholson	1.50	110.00	165.00 phone calls and emails regarding ATS switch code issue and plan of action
10/17/2025	South Walton County Mosquito Control District New Headquarters	Service Order #4 - Admin Bldg Construction Documents, Bidding, CA Construction Administration	Steven Nicholson	2.00	110.00	220.00 Fire watch plan coordination Recived and send off RFI responses 43-45
10/20/2025	South Walton County Mosquito Control District New Headquarters	Service Order #4 - Admin Bldg Construction Documents, Bidding, CA Construction Administration	Steven Nicholson	3.00	110.00	330.00 Request action plan for fire watchreview solution with HG and get approvalPhone calls and coordination with the contractor
10/22/2025	South Walton County Mosquito Control District New Headquarters	Service Order #4 - Admin Bldg Construction Documents, Bidding, CA Construction Administration	Steven Nicholson	2.00	110.00	220.00 Review observation reports from O'Connell StructuralPhone calls and coordination with the contractor
10/23/2025	South Walton County Mosquito Control District New Headquarters	Service Order #4 - Admin Bldg Construction Documents, Bidding, CA Construction Administration	Steven Nicholson	2.00	110.00	220.00 Review observation reports from HGPhone calls and coordination with the contractor
10/27/2025	South Walton County Mosquito Control District New Headquarters	Service Order #4 - Admin Bldg Construction Documents, Bidding, CA Construction Administration	Steven Nicholson	1.50	110.00	165.00 Phone calls and emails regarding punch list items
10/30/2025	South Walton County Mosquito Control District New Headquarters	Service Order #4 - Admin Bldg Construction Documents, Bidding, CA Construction Administration	Steven Nicholson	2.00	110.00	220.00 discuss remedy for punch list itemsReview and answer RFIs for Admin bldg
10/31/2025	South Walton County Mosquito Control District New Headquarters	Service Order #4 - Admin Bldg Construction Documents, Bidding, CA Construction Administration	Steven Nicholson	1.00	110.00	110.00 discuss remedy for punch list itemsReview and answer RFIs for Admin bldg
11/3/2025	South Walton County Mosquito Control District New Headquarters	Service Order #4 - Admin Bldg Construction Documents, Bidding, CA Construction Administration	Steven Nicholson	1.50	110.00	165.00 review pay apps and TCRs
11/4/2025	South Walton County Mosquito Control District New Headquarters	Service Order #4 - Admin Bldg Construction Documents, Bidding, CA Construction Administration	Steven Nicholson	1.50	110.00	165.00 review and answer RFIs
11/6/2025	South Walton County Mosquito Control District New Headquarters	Service Order #4 - Admin Bldg Construction Documents, Bidding, CA Construction Administration	Steven Nicholson	2.50	110.00	275.00 Back puch walk with Contractor and owner
11/10/2025	South Walton County Mosquito Control District New Headquarters	Service Order #4 - Admin Bldg Construction Documents, Bidding, CA Construction Administration	Steven Nicholson	1.00	110.00	110.00 RFIs for gravel parking lot and light diffusers
11/11/2025	South Walton County Mosquito Control District New Headquarters	Service Order #4 - Admin Bldg Construction Documents, Bidding, CA Construction Administration	Steven Nicholson	2.00	110.00	220.00 disucussion with Dan on changing the stem wall from CMU to monolithic pourset up CA folder set up CA logs
11/19/2025	South Walton County Mosquito Control District New Headquarters	Service Order #4 - Admin Bldg Construction Documents, Bidding, CA Construction Administration	Steven Nicholson	1.00	110.00	110.00 Review lift arm gate submittal
11/20/2025	South Walton County Mosquito Control District New Headquarters	Service Order #4 - Admin Bldg Construction Documents, Bidding, CA Construction Administration	Steven Nicholson	2.50	110.00	275.00 Final Punch walk with Contractor
1/16/2026	South Walton County Mosquito Control District New Headquarters	Service Order #4 - Admin Bldg Construction Documents, Bidding, CA Construction Administration	Steven Nicholson	1.00	110.00	110.00 Reveiw contracts from the orginal design
1/22/2026	South Walton County Mosquito Control District New Headquarters	Service Order #4 - Admin Bldg Construction Documents, Bidding, CA Construction Administration	Steven Nicholson	1.50	110.00	165.00 Review change order and answer RFI

1/13/2026	South Walton County Mosquito Control District New Headquarters	Service Order #4 - Admin Bldg Construction Documents, Bidding, CA Construction Administration	Brookelyn Bolin	0.25	110.00	27.50 review paint submittal
1/26/2026	South Walton County Mosquito Control District New Headquarters	Service Order #4 - Admin Bldg Construction Documents, Bidding, CA Construction Administration	Steven Nicholson	1.00	110.00	110.00 Review Pay app
2/5/2026	South Walton County Mosquito Control District New Headquarters	Service Order #4 - Admin Bldg Construction Documents, Bidding, CA Construction Administration	Steven Nicholson	1.00	110.00	110.00 Review change order
1/2/2025	South Walton County Mosquito Control District New Headquarters	Service Order #4 - Admin Bldg Construction Documents, Bidding, CA Construction Administration	Steven Nicholson	1.50	110.00	165.00 RFIs and submittals
1/3/2025	South Walton County Mosquito Control District New Headquarters	Service Order #4 - Admin Bldg Construction Documents, Bidding, CA Construction Administration	Steven Nicholson	2.00	110.00	220.00 RFIs and submittals
3/25/2026	South Walton County Mosquito Control District New Headquarters	Service Order #4 - Admin Bldg Construction Documents, Bidding, CA Construction Administration	Joanna Bonfanti	1.00	60.00	60.00 Review email from Levi with WC Mosquito Control add service for CA and attachments. Draft Add service proposal for Levi's review and email to him.
4/1/2026	South Walton County Mosquito Control District New Headquarters	Service Order #4 - Admin Bldg Construction Documents, Bidding, CA Construction Administration	Joanna Bonfanti	1.00	60.00	60.00 Discussion with Steven regarding additional edits to Add Service proposal.
4/2/2026	South Walton County Mosquito Control District New Headquarters	Service Order #4 - Admin Bldg Construction Documents, Bidding, CA Construction Administration	Joanna Bonfanti	1.00	60.00	60.00 Follow-up with Steven to determine edits needed for Add Services Proposal.
4/7/2026	South Walton County Mosquito Control District New Headquarters	Service Order #4 - Admin Bldg Construction Documents, Bidding, CA Construction Administration	Joanna Bonfanti	0.50	60.00	30.00 Check with Levi and Pat regarding status of Add Services draft proposal and their feedback on last draft.
4/9/2026	South Walton County Mosquito Control District New Headquarters	Service Order #4 - Admin Bldg Construction Documents, Bidding, CA Construction Administration	Joanna Bonfanti	0.50	60.00	30.00 Review revised draft with Pat and Levi's edits incorporated. Edit and return draft to Steven for updates.
				1.005.30		115.747.00

19 April 2026

South Walton Mosquito Control District
c/o Darrin Dunwald
774 N. Highway 393
Santa Rosa Beach, FL 32459

RE: Add Service for South Walton Mosquito Control District Phase II Fleet Maintenance – Architectural Services

Darrin,

Thank you for your continued collaboration with DAG Architects on the above-referenced project. We are pleased to provide this proposal for Additional Services to address the anticipated extended construction time and align DAG's Construction Administration schedule and fee.

The original Construction Administration fee was \$141,387 with an anticipated construction schedule of 12 months, at a rate of \$11,782.25 per month. The Contractor has extended the project out 4 additional months, so DAG requests an Add Service fee of \$47,129 for the additional Construction Administration time.

I. Compensation

The fee for these additional services is as follows:

Description	Fee Type	Amount
Add Service	Lump Sum	\$47,129.00

**Additional bookkeeping and support is available upon request.*

II. Conclusion

We appreciate the opportunity to continue supporting this project and thank you for your trust in our team.

To authorize DAG Architects to proceed with the Additional Services described above, please sign below. Upon receipt of this signed authorization, we will proceed accordingly.

Accepted By:

[Signature]

[Printed Name and Title]

Sincerely,

A handwritten signature in blue ink, appearing to read "Pat Ballasch", with a long horizontal flourish extending to the right.

Pat Ballasch, AIA
President, DAG Architects

Attachments (as applicable):

- Exhibit A – DAG Hourly Billing Rates
- Exhibit B – Reference Documents or Revised Drawings

ADMINISTRATIVE REPORT

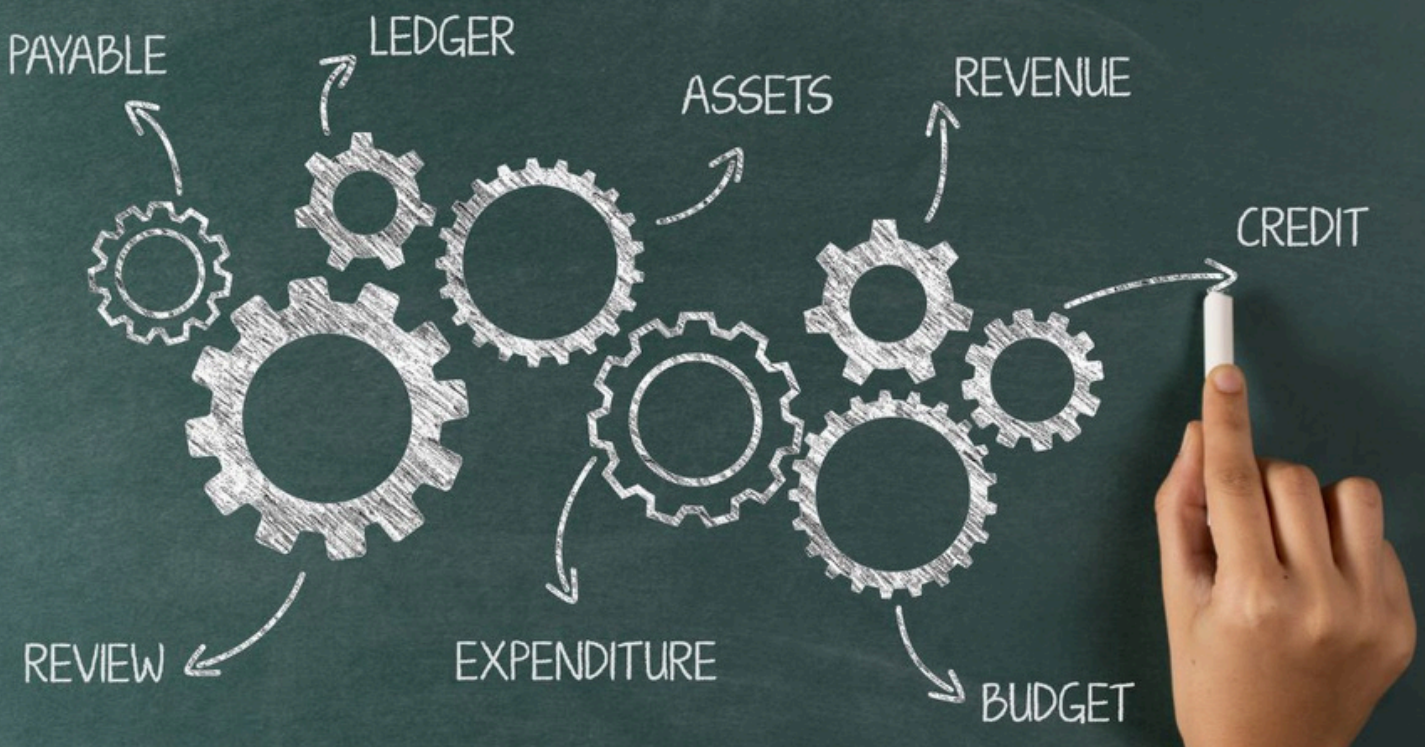

Revenue Review

3:51 PM
05/14/26
Accrual Basis

South Walton County Mosquito Control District Profit & Loss Budget vs. Actual

	Current Year	TOTAL		
		Oct '25 - Apr 26	Budget	\$ Over Budget
Income				
311.000 · AD VALOREM		9,229,914.03	9,867,839.22	-637,925.19
361.000 · Interest income		357,814.25	199,975.00	157,839.25
369.000 · Other Misc Revenues		234.39	1,500.00	-1,265.61
380 · Other Sources		0.00	1,000.00	-1,000.00
Total Income		9,587,962.67	10,070,314.22	-482,351.55

	Previous Year	TOTAL		
		Oct '24 - Apr 25	Budget	\$ Over Budget
Income				
311.000 · AD VALOREM		8,133,576.08	8,637,309.26	-503,733.18
361.000 · Interest income		451,434.19	200,000.00	251,434.19
364.000 · Disposition of Fixed Assets		48,555.00	70,000.00	-21,445.00
369.000 · Other Misc Revenues		1,027.32	1,500.00	-472.68
380 · Other Sources		0.00	1,000.00	-1,000.00
Total Income		8,634,592.59	8,909,809.26	-275,216.67

Trial Balance

2:54 PM
05/14/26
Accrual Basis

South Walton County Mosquito Control District Trial Balance As of April 30, 2026

	Apr 30, 26	
	Debit	Credit
102.004 · Ameris Checking	122,933.33	
102.005 · Ameris Money Market	398,863.32	
102.008 · FL FIT	12,015,738.20	
102.009 · FL CLASS	576.27	
102.045 · Ameris ICS Sweep Checking	548,270.89	
102.055 · Ameris Cash Sweep Money Market	948,660.44	
102.060 · Capital City Bank	3,749,266.70	



April Interest Rates

Ameris:
Checking 2.31%
Money Mkt 2.97%
Florida FIT 3.99%
Florida Class 2.87%
Capital City Bank 0.00%

Expenditure Analysis

Current Expenditures vs. Prior Year and Budget

Reporting Period: October 2025 through April 2026

Scope: Expenditures only. Revenue is not included in this analysis.

Metric	Amount / Rate
Current expenditures	\$8,025,719
Increase vs. prior year	\$2,474,470 (44.6%)
Under budget	\$11,147,900 (41.9% used)
Capital outlay share of current spending	72.7%

Executive Summary

- Current expenditures for the reporting period were \$8,025,719, compared with \$5,551,249 for the same period last year. This is an increase of \$2,474,470, or 44.6%.
- Capital Outlay is the dominant driver: \$5,838,127 of current spending, 72.7% of total expenditures, and 90.9% of the year-over-year increase.
- Excluding Capital Outlay, expenditures were \$2,187,592, up \$224,114 or 11.4% from prior year.
- Non-capital increases were concentrated in Operating Supplies, Chemicals/Solvents/Additives, Operating Expenses, Repair and Maintenance, Supplies/Materials, Training, Travel, and Utilities. Offsets included lower Personal Services, Insurance, and Rentals/Leases.

Summary Comparison

Dollars are rounded to the nearest whole dollar.

Category	Current	Prior Year	\$ Change	% Change
Total Expenditures	\$8,025,719	\$5,551,249	\$2,474,470	44.6%
Capital Outlay	\$5,838,127	\$3,587,771	\$2,250,356	62.7%
Expenditures Excluding Capital Outlay	\$2,187,592	\$1,963,478	\$224,114	11.4%
Category	Current	Budget	Under/(Over) Budget	% Budget Used
Total Expenditures	\$8,025,719	\$19,173,620	\$11,147,900	41.9%
Capital Outlay	\$5,838,127	\$14,068,086	\$8,229,958	41.5%
Expenditures Excluding Capital Outlay	\$2,187,592	\$5,105,534	\$2,917,942	42.8%
Excluding Capital Outlay and Contingency	\$2,187,592	\$4,405,534	\$2,217,942	49.7%

For budget comparisons, Under/(Over) Budget equals Budget less Current. Positive amounts are under budget; amounts in parentheses are over budget.

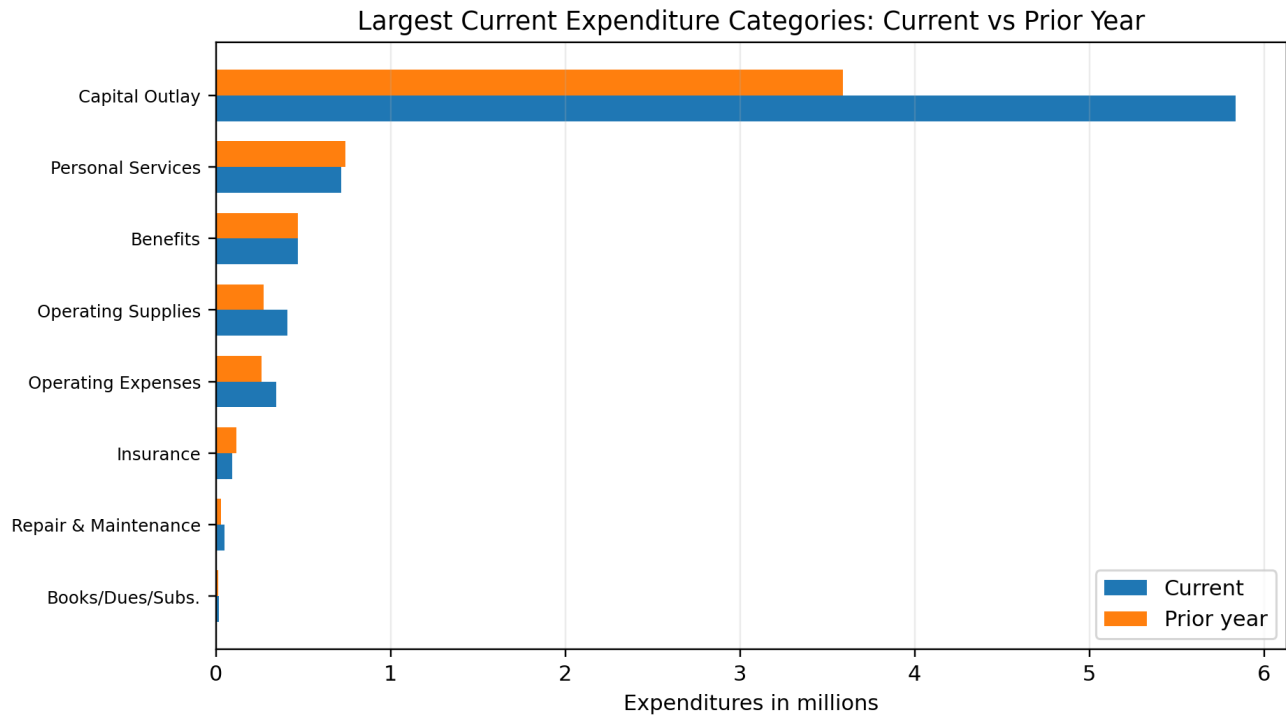

Figure 1. Largest current expenditure categories compared with the prior year.

Prior-Year Expenditure Variance

- Total expenditures increased \$2,474,470. Capital Outlay alone increased by \$2,250,356, which accounts for nearly all of the total increase.
- Outside of capital, the largest increases were Operating Supplies and Operating Expenses, with chemicals and service-related lines carrying most of the movement.

Line / Category	Current	Prior Year	\$ Change	% Change
60.3 - Capital Outlay - New ParkingP#2	\$3,579,796	\$36,962	\$3,542,834	9585.0%
60.5 - Capital Outlay - New Shop P#2	\$1,238,071	\$0	\$1,238,071	N/A
60.2 - Capital Outlay - New Admin	\$817,013	\$2,871,259	(\$2,054,246)	-71.5%
60.15 - DAG - Phase II	\$76,954	\$631,384	(\$554,431)	-87.8%
52 - Operating Supplies	\$408,876	\$275,401	\$133,475	48.5%
52.2 - Chemicals Solvents Additives	\$364,784	\$237,573	\$127,211	53.5%
30 - Operating Expenses	\$345,577	\$261,493	\$84,084	32.2%
34.00 - Other Services	\$77,050	\$28,541	\$48,510	170.0%
31 - Professional Services	\$253,735	\$217,940	\$35,794	16.4%
10 - Personal Services	\$718,503	\$741,491	(\$22,988)	-3.1%
45 - Insurance	\$94,713	\$116,024	(\$21,311)	-18.4%
44 - Rentals & Leases	\$1,333	\$10,893	(\$9,560)	-87.8%

Budget Status

- Total expenditures were \$11,147,900 under budget, with 41.9% of the budget used.
- Capital Outlay was \$8,229,958 under budget and 41.5% used. Capital Outlay plus Contingency accounts for 80.1% of the total under-budget position.
- Excluding Capital Outlay and Contingency, expenditures were \$2,217,942 under budget and 49.7% used.
- Detailed over-budget items are limited in total dollars, but they warrant review because they identify line-item pressure within otherwise under-budget parent categories.

Detailed Line	Current	Budget	Over Budget	% Budget Used
34.00 - Other Services	\$77,050	\$57,900	\$19,150	133.1%
52.12 - Diesel	\$8,367	\$0	\$8,367	N/A
51 - Office Supplies	\$14,620	\$10,000	\$4,620	146.2%
23.4 - Life Insurance	\$4,316	\$4,000	\$316	107.9%

A zero-dollar budget with current spending is shown as over budget with N/A budget utilization.

Capital Outlay Detail

Capital Line	Current	Prior Year	\$ Change	Budget	Under/(Over)	% Used
60.3 - Capital Outlay - New ParkingP#2	\$3,579,796	\$36,962	\$3,542,834	\$5,515,551	\$1,935,755	64.9%
60.5 - Capital Outlay - New Shop P#2	\$1,238,071	\$0	\$1,238,071	\$6,220,365	\$4,982,294	19.9%
60.2 - Capital Outlay - New Admin	\$817,013	\$2,871,259	(\$2,054,246)	\$1,100,876	\$283,863	74.2%
60.15 - DAG - Phase II	\$76,954	\$631,384	(\$554,431)	\$178,529	\$101,575	43.1%
60.1 - DAG	\$8,146	\$18,843	(\$10,698)	\$26,697	\$18,551	30.5%
60 - Capital Outlay - Other	\$118,148	\$29,322	\$88,826	\$991,068	\$872,920	11.9%
60.4 - Capital Outlay - New Chick Coop	\$0	N/A	N/A	\$35,000	\$35,000	0.0%

Recommended Commissioner Discussion Points

- Review the chemical and operating supplies purchasing cycle and inventory plan, since these costs are up significantly from the prior year but remain below budget.
- Review Other Services, Office Supplies, Diesel, and Life Insurance line items because they are over budget at the detailed level.
- Continue monitoring non-capital expenditure run rate for the remainder of the fiscal year, particularly Operating Expenses and Repair and Maintenance.

Appendix A: Major Expenditure Categories

This table is limited to expenditure categories and excludes all revenue-related lines. Under/(Over) Budget equals Budget less Current.

Category	Current	Prior Year	\$ Change	% Change	Budget	Under/(Over) Budget	% Budget Used
10 - Personal Services	\$718,503	\$741,491	(\$22,988)	-3.1%	\$1,570,700	\$852,197	45.7%
20 - Personal Services Benefits	\$470,388	\$469,309	\$1,080	0.2%	\$796,756	\$326,368	59.0%
30 - Operating Expenses	\$345,577	\$261,493	\$84,084	32.2%	\$511,300	\$165,723	67.6%
40 - Travel & Per Diem	\$16,612	\$9,120	\$7,492	82.1%	\$44,500	\$27,888	37.3%
41 - Communication Services	\$7,439	\$6,235	\$1,204	19.3%	\$19,000	\$11,561	39.2%
42 - Freight Services	\$1,164	\$1,003	\$161	16.0%	\$6,400	\$5,236	18.2%
43 - Utility Services	\$14,928	\$6,827	\$8,101	118.7%	\$29,640	\$14,712	50.4%
44 - Rentals & Leases	\$1,333	\$10,893	(\$9,560)	-87.8%	\$10,000	\$8,667	13.3%
45 - Insurance	\$94,713	\$116,024	(\$21,311)	-18.4%	\$168,000	\$73,287	56.4%
46 - Repair & Maintenance Services	\$48,571	\$30,182	\$18,389	60.9%	\$123,500	\$74,929	39.3%
47 - Printing & Binding	\$236	\$120	\$116	96.6%	\$3,000	\$2,764	7.9%
48 - Promotional Activities	\$1,705	\$5,081	(\$3,376)	-66.4%	\$8,000	\$6,295	21.3%
49 - Other Current Charges	\$3,572	\$5,609	(\$2,037)	-36.3%	\$6,000	\$2,428	59.5%
50 - Supplies/Materials	\$19,022	\$7,063	\$11,959	169.3%	\$25,000	\$5,978	76.1%
52 - Operating Supplies	\$408,876	\$275,401	\$133,475	48.5%	\$1,011,000	\$602,124	40.4%
54 - Books, Dues & Subscriptions	\$19,733	\$12,194	\$7,540	61.8%	\$43,000	\$23,267	45.9%
55 - Training	\$15,219	\$5,433	\$9,786	180.1%	\$29,738	\$14,519	51.2%
60 - Capital Outlay	\$5,838,127	\$3,587,771	\$2,250,356	62.7%	\$14,068,086	\$8,229,958	41.5%
89 - Contingency	\$0	N/A	N/A	N/A	\$700,000	\$700,000	0.0%
66900 - Reconciliation Discrepancies	\$0	\$0	\$0	N/A	N/A	N/A	N/A
Total Expense	\$8,025,719	\$5,551,249	\$2,474,470	44.6%	\$19,173,620	\$11,147,900	41.9%

Source: QuickBooks exports provided by staff. Revenue excluded.

FINANCIAL REVIEW

SUMMARY YEAR TO DATE

Income	\$20,264,548
Expenses	\$2,307,000
Construction	\$5,670,368

BALANCE **\$12,287,181**

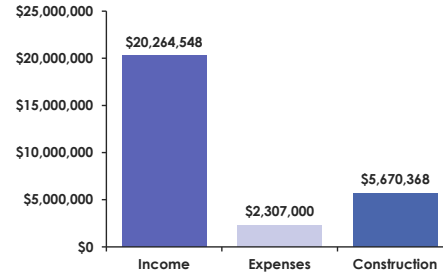

INCOME

Item	Oct	Nov	Dec	Jan	Feb	Mar	Apr	Total	% of Budget
Ad Valorem	92,229.53	1,942,309.45	5,613,753.39	616,318.88	311,943.12	252,320.76	401,038.90	\$ 9,229,914.03	86.91%
Interest Income	48,229.06	43,905.36	51,018.79	65,400.12	53,747.30	50,417.89	45,095.73	\$ 357,814.25	131.17%
Misc Income	-	-	234.39			-		\$ 234.39	15.63%
Other	-	-				-		\$ -	0.00%
Carryover - Prior Year Surplus					10,676,585.74	-		\$ 10,676,585.74	
Total	\$ 140,458.59	\$ 1,986,214.81	\$ 5,665,006.57	\$ 681,719.00	\$ 11,042,276.16	\$ 302,738.65	\$ 446,134.63	\$ 20,264,548.41	

EXPENSES (Not including construction)

Item	Oct	Nov	Dec	Jan	Feb	Mar	Apr	Total	Average
Personal Services	89,853.83	93,812.24	141,849.17	93,509.51	99,137.43	98,605.93	101,735.01	\$ 718,503	\$ 102,643
Personal Services - Benefits	60,353.85	57,159.01	76,361.56	73,748.48	66,302.40	67,599.99	68,622.87	\$ 470,148	\$ 67,164
Operating Expenses	34,781.53	45,063.75	122,691.03	39,498.99	16,225.89	44,274.31	43,041.97	\$ 345,577	\$ 49,368
Travel & Per Diem	145.06	-	7,100.80	1,922.00	4,946.94	1,929.94	567.00	\$ 16,612	\$ 2,373
Communication Services	899.65	951.40	955.49	954.49	640.74	2,025.08	1,012.29	\$ 7,439	\$ 1,063
Freight Services	232.63	323.65	223.55	-	-	63.31	320.79	\$ 1,164	\$ 166
Utility Services	1,830.64	1,151.37	1,599.46	1,956.22	2,562.07	3,590.89	2,236.90	\$ 14,928	\$ 2,133
Rental & Leases	-	-	672.99	-	385.00	275.00	-	\$ 1,333	\$ 190
Insurance	105,986.78	(5,321.00)	-	2,671.00	-	-	(8,623.82)	\$ 94,713	\$ 13,530
Repairs & Maintenance	3,728.37	1,777.78	26,977.14	4,393.33	5,028.95	5,308.55	2,856.69	\$ 50,071	\$ 7,153
Printing & Binding	59.98	-	-	175.96	-	-	-	\$ 236	\$ 34

EXPENSES (Not including construction)

Item	Oct	Nov	Dec	Jan	Feb	Mar	Apr	Total	Average
Promotional Activities	-	-	-	122.83	119.23	1,357.95	104.64	\$ 1,705	\$ 244
Other Charges	442.02	711.95	547.43	385.60	685.16	266.76	533.56	\$ 3,572	\$ 510
Office Supplies	4,364.49	992.94	816.43	3,602.07	5,526.46	1,838.88	1,880.67	\$ 19,022	\$ 2,717
Gassonline/Oil/Lube	4,008.69	3,376.41	2,068.32	1,403.17	3,221.51	4,051.60	4,819.66	\$ 22,949	\$ 3,278
Chemicals	93,349.60	22,092.00	42,614.00	62,491.20	27,040.00	-	117,197.60	\$ 364,784	\$ 52,112
Protective Clothing	315.60	363.04	95.96	192.79	451.49	1,267.72	(89.99)	\$ 2,597	\$ 371
Misc Supplies	1,691.95	777.56	1,916.18	4,029.92	3,342.07	1,800.27	4,536.38	\$ 18,094	\$ 2,585
Tools & Implements	-	-	-	-	59.99	325.00	66.49	\$ 451	\$ 64
Publications & Dues	11,147.37	-	259.50	287.50	500.00	7,500.00	39.00	\$ 19,733	\$ 2,819
Training	3,806.85	-	4,639.00	2,640.00	870.26	3,113.26	150.00	\$ 15,219	\$ 2,174
Capital Outlay* (No Construction Cost)	-	-	-	8,525.00	-	-	109,622.93	\$ 118,148	\$ 16,878
Total	\$ 416,998.89	\$ 223,232.10	\$ 431,388.01	\$ 302,510.06	\$ 237,045.59	\$ 245,194.44	\$450,630.64	\$ 2,306,999.73	\$ 329,571

Construction Costs

Item	Oct	Nov	Dec	Jan	Feb	Mar	Apr	Total	Budget
DAG - Admin Bldg	-	-	4,560.00	-	-	3,585.50	-	\$ 8,146	\$ 26,697
DAG - PHASE 2	18,655.20	9,907.50	9,290.00	8,975.00	8,975.00	8,975.00	12,176.00	\$ 76,954	\$ 178,529
Administrative Bldg	74,529.50	58,609.95	103,273.70	139,831.54	180,817.23	210,355.68	2,300.00	\$ 769,718	\$ 1,100,876
Phase 2 A - Parking Garage	458,157.54	743,263.18	857,197.56	283,704.86	502,160.93	497,188.45	235,807.29	\$ 3,577,480	\$ 5,515,551
Phase 2 B - Fleet Maintenance	-	4,914.30	23,446.00	114,622.00	173,701.55	201,184.70	720,202.64	\$ 1,238,071	\$ 6,095,365
Chicken Coop	-	-	-	-	-	-	-	\$ -	\$ 35,000
Total	\$ 551,342.24	\$ 816,694.93	\$ 997,767.26	\$ 547,133.40	\$ 865,654.71	\$ 921,289.33	\$970,485.93	\$ 5,670,367.80	\$ 12,952,017.92

South Walton County Mosquito Control District
Profit & Loss Budget vs. Actual
October 2025 through April 2026

								TOTAL			
	Oct 25	Nov 25	Dec 25	Jan 26	Feb 26	Mar 26	Apr 26	Oct '25 - Apr 26	Budget	\$ Over Budget	% of Budget
Income											
311.000 · AD VALOREM											
311.001 · Prior Year Taxes/Other	207.60	0.00	0.00	0.00	0.00	0.00	0.00	207.60			
311.000 · AD VALOREM - Other	92,021.93	1,942,309.45	5,613,753.39	616,318.88	311,943.12	252,320.76	401,038.90	9,229,706.43	9,867,839.22	-638,132.79	93.53%
Total 311.000 · AD VALOREM	92,229.53	1,942,309.45	5,613,753.39	616,318.88	311,943.12	252,320.76	401,038.90	9,229,914.03	9,867,839.22	-637,925.19	93.54%
361.000 · Interest income	48,229.06	43,905.36	51,018.79	65,400.12	53,747.30	50,417.89	45,095.73	357,814.25	199,975.00	157,839.25	178.93%
369.000 · Other Misc Revenues	0.00	0.00	234.39	0.00	0.00	0.00	0.00	234.39	1,500.00	-1,265.61	15.63%
380 · Other Sources	0.00	0.00	0.00	0.00	0.00	0.00	0.00	0.00	1,000.00	-1,000.00	0.0%
Total Income	140,458.59	1,986,214.81	5,665,006.57	681,719.00	365,690.42	302,738.65	446,134.63	9,587,962.67	10,070,314.22	-482,351.55	95.21%
Gross Profit	140,458.59	1,986,214.81	5,665,006.57	681,719.00	365,690.42	302,738.65	446,134.63	9,587,962.67	10,070,314.22	-482,351.55	95.21%
Expense											
10 · PERSONAL SERVICES											
11 · Commissioner Salaries	1,107.72	1,107.72	1,661.58	1,107.72	1,107.72	1,107.72	1,107.72	8,307.90	14,400.00	-6,092.10	57.69%
12 · Regular Salaries and wages											
16 · Compensated annual leave	4,409.55	5,057.43	8,286.01	12,282.57	6,149.25	4,666.78	4,578.23	45,429.82			
12 · Regular Salaries and wages - Other	84,180.84	87,544.89	131,745.29	80,061.85	91,377.08	92,795.01	95,889.56	663,594.52	1,516,300.00	-852,705.48	43.76%
Total 12 · Regular Salaries and wages	88,590.39	92,602.32	140,031.30	92,344.42	97,526.33	97,461.79	100,467.79	709,024.34	1,516,300.00	-807,275.66	46.76%
13 · Other salaries and wages	0.00	0.00	0.00	0.00	0.00	0.00	0.00	0.00	25,000.00	-25,000.00	0.0%
14 · Overtime	155.72	102.20	156.29	57.37	503.38	36.42	159.50	1,170.88	15,000.00	-13,829.12	7.81%
10 · PERSONAL SERVICES - Other	0.00	0.00	0.00	0.00	0.00	0.00	0.00	0.00			
Total 10 · PERSONAL SERVICES	89,853.83	93,812.24	141,849.17	93,509.51	99,137.43	98,605.93	101,735.01	718,503.12	1,570,700.00	-852,196.88	45.74%
20 · PERSONAL SERVICES BENEFITS											
21 · FICA Taxes	6,460.57	6,715.19	10,511.24	6,681.84	7,164.05	7,093.80	7,333.22	51,959.91	120,000.00	-68,040.09	43.3%
21.3 · Federal Unemployment	74.04	72.68	42.13	505.58	287.54	31.66	27.62	1,041.25	3,000.00	-1,958.75	34.71%
22 · Retirement contributions											
22.2 · FRS paid by District	14,694.34	15,469.00	23,683.70	15,663.12	16,354.56	16,324.72	16,339.79	118,529.23	256,356.00	-137,826.77	46.24%
Total 22 · Retirement contributions	14,694.34	15,469.00	23,683.70	15,663.12	16,354.56	16,324.72	16,339.79	118,529.23	256,356.00	-137,826.77	46.24%
23 · Life and Health Insurance											
23.1 · AFLAC	-55.20	-107.00	-392.96	57.02	57.02	28.02	59.44	-353.66			
23.3 · Vision	33.75	32.36	-85.15	43.26	43.26	44.84	44.84	157.16			
23.4 · Life Insurance	759.54	395.84	636.39	621.14	621.14	621.14	660.79	4,315.98	4,000.00	315.98	107.9%
23.5 · STD/LTD	1,090.36	559.67	1,005.31	967.12	967.12	967.12	1,668.48	7,225.18	25,000.00	-17,774.82	28.9%
23.55 · Dental	676.48	560.92	563.78	737.83	737.83	771.62	771.62	4,820.08	18,000.00	-13,179.92	26.78%
23.7 · Supplement Insurance Program	20.00	20.00	30.00	20.00	20.00	20.00	20.00	150.00			
23.8 · BCBS of Florida - Medical Insur	33,910.65	31,448.53	38,172.10	39,007.75	37,803.86	39,007.75	39,007.75	258,358.39	300,000.00	-41,641.61	86.12%
Total 23 · Life and Health Insurance	36,435.58	32,910.32	39,929.47	41,454.12	40,250.23	41,460.49	42,232.92	274,673.13	347,000.00	-72,326.87	79.16%

South Walton County Mosquito Control District
Profit & Loss Budget vs. Actual
October 2025 through April 2026

								TOTAL			
	Oct 25	Nov 25	Dec 25	Jan 26	Feb 26	Mar 26	Apr 26	Oct '25 - Apr 26	Budget	\$ Over Budget	% of Budget
24 · WORKERS COMP	0.00	0.00	0.00	0.00	0.00	0.00	0.00	0.00	15,000.00	-15,000.00	0.0%
25 · Unemployment Compensation	0.00	0.00	0.00	2,475.00	0.00	0.00	0.00	2,475.00	15,000.00	-12,525.00	16.5%
26 · Other postemployment benefits											
26.2 · Jose Hernandez	1,344.66	963.36	1,217.56	3,710.36	1,217.56	1,217.56	1,344.66	11,015.72	20,200.00	-9,184.28	54.53%
26.3 · Geraldine Via	1,344.66	1,028.46	1,344.66	3,258.46	1,028.46	1,344.66	1,344.66	10,694.02	20,200.00	-9,505.98	52.94%
Total 26 · Other postemployment benefits	2,689.32	1,991.82	2,562.22	6,968.82	2,246.02	2,562.22	2,689.32	21,709.74	40,400.00	-18,690.26	53.74%
Total 20 · PERSONAL SERVICES BENEFITS	60,353.85	57,159.01	76,728.76	73,748.48	66,302.40	67,472.89	68,622.87	470,388.26	796,756.00	-326,367.74	59.04%
30 · OPERATING EXPENSES											
30.3 · Kristine Faulk	150.00	150.00	150.00	150.00	150.00	150.00	150.00	1,050.00	1,800.00	-750.00	58.33%
30.5 · J Doug Liles	150.00	150.00	150.00	150.00	150.00	150.00	150.00	1,050.00	1,800.00	-750.00	58.33%
30.6 · Stephen Young	150.00	150.00	150.00	150.00	150.00	150.00	150.00	1,050.00	1,800.00	-750.00	58.33%
30.9 · Commissioner Monthly Stipend	0.00	0.00	0.00	0.00	225.00	0.00	0.00	225.00			
31 · Professional Services											
31.1 · Property Appraiser Fees	23,594.12	0.00	0.00	23,594.12	0.00	0.00	23,594.12	70,782.36	100,000.00	-29,217.64	70.78%
31.2 · Tax Collector Fees	4.14	38,963.69	112,275.07	12,326.37	6,238.87	5,046.41	7,912.67	182,767.22	200,000.00	-17,232.78	91.38%
31.4 · Medical Services	0.00	0.00	88.00	48.00	0.00	0.00	49.00	185.00	5,000.00	-4,815.00	3.7%
Total 31 · Professional Services	23,598.26	38,963.69	112,363.07	35,968.49	6,238.87	5,046.41	31,555.79	253,734.58	305,000.00	-51,265.42	83.19%
31.3 · Legal and Engineering Service											
31.6 · Legal Services	3,787.50	1,100.00	3,722.50	0.00	2,797.50	0.00	0.00	11,407.50	25,000.00	-13,592.50	45.63%
31.8 · Albrecht Engineering	0.00	0.00	0.00	0.00	0.00	0.00	0.00	0.00	78,000.00	-78,000.00	0.0%
31.3 · Legal and Engineering Service - Other	0.00	0.00	0.00	0.00	0.00	0.00	10.00	10.00			
Total 31.3 · Legal and Engineering Service	3,787.50	1,100.00	3,722.50	0.00	2,797.50	0.00	10.00	11,417.50	103,000.00	-91,582.50	11.09%
32 · ACCOUNTING & AUDITING	0.00	0.00	0.00	0.00	0.00	0.00	0.00	0.00	40,000.00	-40,000.00	0.0%
34.00 · Other Services											
34.12 · Other services IT Hosting	0.00	0.00	0.00	46.38	0.00	0.00	23.19	69.57			
34.13 · NetData Consulting Services	0.00	2,374.00	2,374.00	2,374.00	2,374.00	2,374.00	2,374.00	14,244.00			
34.14 · LiveOak Fiber	169.00	0.00	169.00	169.00	169.00	169.00	0.00	845.00			
34.19 · IPS Contract Service Plan	0.00	0.00	165.00	0.00	165.00	0.00	0.00	330.00			
34.20 · UNIFIRST	458.80	287.55	478.51	369.23	288.85	429.05	484.42	2,796.41			
34.32 · EverOn System Montioring	0.00	1,665.75	720.70	0.00	799.29	0.00	0.00	3,185.74			
34.33 · Other Contractual Services	6,317.97	222.76	673.25	121.89	93.38	33,705.85	3,944.57	45,079.67			
34.00 · Other Services - Other	0.00	0.00	1,575.00	0.00	2,625.00	2,100.00	4,200.00	10,500.00	57,900.00	-47,400.00	18.14%
Total 34.00 · Other Services	6,945.77	4,550.06	6,155.46	3,080.50	6,514.52	38,777.90	11,026.18	77,050.39	57,900.00	19,150.39	133.08%
Total 30 · OPERATING EXPENSES	34,781.53	45,063.75	122,691.03	39,498.99	16,225.89	44,274.31	43,041.97	345,577.47	511,300.00	-165,722.53	67.59%
40 · TRAVEL & PER DIEM											
40.1 · PER DIEM OR MEALS	248.00	0.00	1,250.00	1,922.00	356.94	601.00	0.00	4,377.94	12,000.00	-7,622.06	36.48%

South Walton County Mosquito Control District
Profit & Loss Budget vs. Actual
October 2025 through April 2026

								TOTAL			
	Oct 25	Nov 25	Dec 25	Jan 26	Feb 26	Mar 26	Apr 26	Oct '25 - Apr 26	Budget	\$ Over Budget	% of Budget
40.2 · INCIDENTAL TRAVEL	15.98	0.00	30.00	0.00	0.00	106.74	0.00	152.72	2,000.00	-1,847.28	7.64%
40.3 · PRIVIATE VEHICLES	0.00	0.00	1,428.00	0.00	0.00	52.20	0.00	1,480.20	5,500.00	-4,019.80	26.91%
40.4 · Hotel	-118.92	0.00	4,392.80	0.00	4,590.00	1,170.00	567.00	10,600.88	20,000.00	-9,399.12	53.0%
40.5 · Air Lines	0.00	0.00	0.00	0.00	0.00	0.00	0.00	0.00	5,000.00	-5,000.00	0.0%
40 · TRAVEL & PER DIEM - Other	0.00	0.00	0.00	0.00	0.00	0.00	0.00	0.00	0.00	0.00	0.0%
Total 40 · TRAVEL & PER DIEM	145.06	0.00	7,100.80	1,922.00	4,946.94	1,929.94	567.00	16,611.74	44,500.00	-27,888.26	37.33%
41 · COMMUNICATION SERVICES											
41.1 · Cellular Service	899.65	711.77	713.40	713.40	727.64	1,543.52	772.01	6,081.39	8,000.00	-1,918.61	76.02%
41.2 · Office Phone & Internet	0.00	239.63	242.09	241.09	-86.90	481.56	240.28	1,357.75	5,000.00	-3,642.25	27.16%
41 · COMMUNICATION SERVICES - Other	0.00	0.00	0.00	0.00	0.00	0.00	0.00	0.00	6,000.00	-6,000.00	0.0%
Total 41 · COMMUNICATION SERVICES	899.65	951.40	955.49	954.49	640.74	2,025.08	1,012.29	7,439.14	19,000.00	-11,560.86	39.15%
42 · FREIGHT SERVICES	232.63	323.65	223.55	0.00	0.00	63.31	320.79	1,163.93	6,400.00	-5,236.07	18.19%
43 · UTILITY SERVICES											
43.02 · Water/Sewer	224.77	224.77	224.77	224.77	638.36	226.72	278.73	2,042.89	3,000.00	-957.11	68.1%
43.03 · Electrical	1,364.27	757.97	1,213.36	1,564.48	1,756.70	1,876.04	1,798.56	10,331.38	22,000.00	-11,668.62	46.96%
43.04 · GARBAGE SOLID WASTE SERVICES	107.60	107.60	107.60	107.60	107.60	107.60	107.60	753.20	2,500.00	-1,746.80	30.13%
43.05 · Gas Service	134.00	61.03	53.73	59.37	59.41	1,380.53	52.01	1,800.08	2,140.00	-339.92	84.12%
Total 43 · UTILITY SERVICES	1,830.64	1,151.37	1,599.46	1,956.22	2,562.07	3,590.89	2,236.90	14,927.55	29,640.00	-14,712.45	50.36%
44 · RENTALS & LEASES	0.00	0.00	672.99	0.00	385.00	275.00	0.00	1,332.99	10,000.00	-8,667.01	13.33%
45 · INSURANCE											
45.3 · FLOOD INSURANCE	0.00	0.00	0.00	2,671.00	0.00	0.00	0.00	2,671.00	5,000.00	-2,329.00	53.42%
45.5 · Workers Comp Insurance	25,320.78	0.00	0.00	0.00	0.00	0.00	-8,623.82	16,696.96	35,000.00	-18,303.04	47.71%
45.6 · General liability	80,666.00	-5,321.00	0.00	0.00	0.00	0.00	0.00	75,345.00	98,000.00	-22,655.00	76.88%
45.7 · Drone Insurance	0.00	0.00	0.00	0.00	0.00	0.00	0.00	0.00	30,000.00	-30,000.00	0.0%
Total 45 · INSURANCE	105,986.78	-5,321.00	0.00	2,671.00	0.00	0.00	-8,623.82	94,712.96	168,000.00	-73,287.04	56.38%
46 · REPAIR & MAINTENANCE SERVICES											
46.11 · Maint Bldg/Ground by others	0.00	0.00	0.00	0.00	0.00	0.00	0.00	0.00	5,000.00	-5,000.00	0.0%
46.2 · Maintenance of Automotive Equip	52.14	0.00	0.00	0.00	16.17	0.00	0.00	68.31	45,000.00	-44,931.69	0.15%
46.3 · Maintenance of Equipment Office											
46.31 · Software Maintenance Office Eq	339.98	772.00	24,256.17	1,466.99	2,812.29	1,797.48	257.50	31,702.41	45,000.00	-13,297.59	70.45%
46.34 · NetData	1,700.00	670.00	0.00	0.00	1,370.50	2,581.50	0.00	6,322.00			
46.3 · Maintenance of Equipment Office - Other	0.00	0.00	0.00	0.00	0.00	0.00	0.00	0.00	1,000.00	-1,000.00	0.0%
Total 46.3 · Maintenance of Equipment Office	2,039.98	1,442.00	24,256.17	1,466.99	4,182.79	4,378.98	257.50	38,024.41	46,000.00	-7,975.59	82.66%
46.4 · Maint Other Equipment by others	61.57	0.00	0.00	0.00	0.00	0.00	590.85	652.42	4,500.00	-3,847.58	14.5%
46.5 · Maint of Build & Grounds by Dis	296.10	0.00	35.97	216.98	219.83	25.98	49.99	844.85	3,000.00	-2,155.15	28.16%
46.6 · Maint of equipment by District	1,278.58	335.78	1,185.00	2,709.36	610.16	903.59	1,958.35	8,980.82	20,000.00	-11,019.18	44.9%

South Walton County Mosquito Control District
Profit & Loss Budget vs. Actual
October 2025 through April 2026

								TOTAL			
	Oct 25	Nov 25	Dec 25	Jan 26	Feb 26	Mar 26	Apr 26	Oct '25 - Apr 26	Budget	\$ Over Budget	% of Budget
Total 46 · REPAIR & MAINTENANCE SERVICES	3,728.37	1,777.78	25,477.14	4,393.33	5,028.95	5,308.55	2,856.69	48,570.81	123,500.00	-74,929.19	39.33%
47 · PRINTING & BINDING	59.98	0.00	0.00	175.96	0.00	0.00	0.00	235.94	3,000.00	-2,764.06	7.87%
48 · PROMOTIONAL ACTIVITIES	0.00	0.00	0.00	122.83	119.23	1,357.95	104.64	1,704.65	8,000.00	-6,295.35	21.31%
49 · OTHER CURRENT CHARGES											
49.1 · Other Government Agencies	6.08	200.00	0.00	6.08	19.87	242.01	227.56	701.60			
49.2 · advertising required by law	93.25	13.50	216.25	11.25	188.97	24.75	306.00	853.97			
49 · OTHER CURRENT CHARGES - Other	342.69	498.45	331.18	368.27	476.32	0.00	0.00	2,016.91	6,000.00	-3,983.09	33.62%
Total 49 · OTHER CURRENT CHARGES	442.02	711.95	547.43	385.60	685.16	266.76	533.56	3,572.48	6,000.00	-2,427.52	59.54%
50 · SUPPLIES/MATERIALS											
50.1 · Culligan	48.51	0.00	0.00	0.00	0.00	0.00	0.00	48.51			
50.3 · Employee Committee	3,525.00	297.79	137.28	0.00	0.00	392.90	0.00	4,352.97	10,000.00	-5,647.03	43.53%
51 · Office Supplies	790.98	695.15	679.15	3,602.07	5,526.46	1,445.98	1,880.67	14,620.46	10,000.00	4,620.46	146.21%
50 · SUPPLIES/MATERIALS - Other	0.00	0.00	0.00	0.00	0.00	0.00	0.00	0.00	5,000.00	-5,000.00	0.0%
Total 50 · SUPPLIES/MATERIALS	4,364.49	992.94	816.43	3,602.07	5,526.46	1,838.88	1,880.67	19,021.94	25,000.00	-5,978.06	76.09%
52 · Operating Supplies											
52.1 · Gasoline Oil Lubricant											
52.11 · Gasoline	1,989.82	1,999.93	946.49	988.82	2,254.55	1,755.58	3,210.06	13,145.25			
52.12 · Diesel	1,581.98	1,376.48	899.70	0.00	966.96	2,006.34	1,536.00	8,367.46	0.00	8,367.46	100.0%
52.13 · Gasoline other than District	90.90	0.00	147.14	339.36	0.00	154.83	73.60	805.83			
52.1 · Gasoline Oil Lubricant - Other	345.99	0.00	74.99	74.99	0.00	134.85	0.00	630.82	50,000.00	-49,369.18	1.26%
Total 52.1 · Gasoline Oil Lubricant	4,008.69	3,376.41	2,068.32	1,403.17	3,221.51	4,051.60	4,819.66	22,949.36	50,000.00	-27,050.64	45.9%
52.2 · Chemicals Solvents Additives											
52.204 · VMX Vectomax FG	16,374.00	0.00	16,374.00	33,696.00	0.00	0.00	0.00	66,444.00			
52.205 · Altosid P-35	32,400.00	0.00	0.00	0.00	0.00	0.00	33,360.00	65,760.00			
52.208 · Duplex-G Granular IGR	0.00	0.00	26,240.00	27,040.00	27,040.00	0.00	0.00	80,320.00			
52.22 · VLX VCTOLEX WDG	0.00	0.00	0.00	1,755.20	0.00	0.00	0.00	1,755.20			
52.25 · Fourstar BTI CRG 35 lb	41,975.20	22,092.00	0.00	0.00	0.00	0.00	0.00	64,067.20			
52.26 · Altosid XR Slim	2,600.40	0.00	0.00	0.00	0.00	0.00	0.00	2,600.40			
52.27 · KONTROL 30-30	0.00	0.00	0.00	0.00	0.00	0.00	60,737.60	60,737.60			
52.2 · Chemicals Solvents Additives - Other	0.00	0.00	0.00	0.00	0.00	0.00	23,100.00	23,100.00	900,000.00	-876,900.00	2.57%
Total 52.2 · Chemicals Solvents Additives	93,349.60	22,092.00	42,614.00	62,491.20	27,040.00	0.00	117,197.60	364,784.40	900,000.00	-535,215.60	40.53%
52.3 · Clothing and Wearing Apparel											
52.31 · uniforms	315.60	0.00	-20.65	0.00	0.00	506.08	0.00	801.03			
52.32 · Boots	0.00	363.04	0.00	133.00	451.49	761.64	-89.99	1,619.18			
52.33 · Misc. clothing	0.00	0.00	116.61	59.79	0.00	0.00	0.00	176.40			
52.3 · Clothing and Wearing Apparel - Other	0.00	0.00	0.00	0.00	0.00	0.00	0.00	0.00	10,000.00	-10,000.00	0.0%

South Walton County Mosquito Control District
Profit & Loss Budget vs. Actual
October 2025 through April 2026

								TOTAL			
	Oct 25	Nov 25	Dec 25	Jan 26	Feb 26	Mar 26	Apr 26	Oct '25 - Apr 26	Budget	\$ Over Budget	% of Budget
Total 52.3 · Clothing and Wearing Apparel	315.60	363.04	95.96	192.79	451.49	1,267.72	-89.99	2,596.61	10,000.00	-7,403.39	25.97%
52.4 · Misc Supplies & Incidentals											
52.41 · Yellow Fly	0.00	0.00	0.00	0.00	0.00	91.05	0.00	91.05	5,000.00	-4,908.95	1.82%
52.411 · UAS - Drone Supplies	0.00	0.00	81.95	138.39	199.46	106.93	5.98	532.71	2,000.00	-1,467.29	26.64%
52.42 · Mosquito	174.98	0.00	143.00	780.36	223.07	0.00	650.70	1,972.11	5,000.00	-3,027.89	39.44%
52.43 · DITCHES	0.00	0.00	0.00	44.95	96.96	0.00	527.91	669.82	10,000.00	-9,330.18	6.7%
52.44 · Safety	1,169.99	0.00	0.00	37.90	628.31	102.90	129.99	2,069.09	4,000.00	-1,930.91	51.73%
52.45 · Shop	177.10	265.30	382.77	387.06	585.23	123.54	185.98	2,106.98	5,000.00	-2,893.02	42.14%
52.47 · Chickens	0.00	129.52	944.04	305.71	193.08	699.60	496.08	2,768.03	5,000.00	-2,231.97	55.36%
52.48 · Lab	169.88	382.74	364.42	2,335.55	1,415.96	351.25	2,539.74	7,559.54	11,000.00	-3,440.46	68.72%
52.4 · Misc Supplies & Incidentals - Other	0.00	0.00	0.00	0.00	0.00	325.00	0.00	325.00			
Total 52.4 · Misc Supplies & Incidentals	1,691.95	777.56	1,916.18	4,029.92	3,342.07	1,800.27	4,536.38	18,094.33	47,000.00	-28,905.67	38.5%
52.5 · Tool and small implements	0.00	0.00	0.00	0.00	59.99	325.00	66.49	451.48	4,000.00	-3,548.52	11.29%
Total 52 · Operating Supplies	99,365.84	26,609.01	46,694.46	68,117.08	34,115.06	7,444.59	126,530.14	408,876.18	1,011,000.00	-602,123.82	40.44%
54 · BOOKS, DUES & SUBSCRIPTIONS	11,147.37	0.00	259.50	287.50	500.00	7,500.00	39.00	19,733.37	43,000.00	-23,266.63	45.89%
55 · TRAINING											
55.1 · Conferences	0.00	0.00	0.00	0.00	0.00	1,732.00	0.00	1,732.00			
55.2 · Classroom Education	17.85	0.00	0.00	1,800.00	33.26	0.00	0.00	1,851.11			
55.3 · Virtual Training	49.00	0.00	0.00	0.00	0.00	632.26	150.00	831.26			
55 · TRAINING - Other	3,740.00	0.00	4,639.00	840.00	837.00	749.00	0.00	10,805.00	29,738.00	-18,933.00	36.33%
Total 55 · TRAINING	3,806.85	0.00	4,639.00	2,640.00	870.26	3,113.26	150.00	15,219.37	29,738.00	-14,518.63	51.18%
60 · CAPITAL OUTLAY											
60.1 · DAG	0.00	0.00	4,560.00	0.00	0.00	3,585.50	0.00	8,145.50	26,696.70	-18,551.20	30.51%
60.15 · DAG - Phase II	18,655.20	9,907.50	9,290.00	8,975.00	8,975.00	8,975.00	12,176.00	76,953.70	178,528.80	-101,575.10	43.1%
60.2 · Capital Outlay – New Admin											
60.25 · New Admin Bldg Furn/Fix	0.00	0.00	0.00	0.00	0.00	0.00	2,300.00	2,300.00			
60.2 · Capital Outlay – New Admin - Other	74,529.50	58,609.95	103,274.30	139,762.60	180,817.23	210,355.68	47,363.93	814,713.19	1,100,876.42	-286,163.23	74.01%
Total 60.2 · Capital Outlay – New Admin	74,529.50	58,609.95	103,274.30	139,762.60	180,817.23	210,355.68	49,663.93	817,013.19	1,100,876.42	-283,863.23	74.22%
60.3 · Capital Outlay - New ParkingP#2	458,157.54	743,263.18	859,444.74	283,773.80	502,160.93	497,188.45	235,807.29	3,579,795.93	5,515,551.00	-1,935,755.07	64.9%
60.4 · Capital Outlay - New Chick Coop	0.00	0.00	0.00	0.00	0.00	0.00	0.00	0.00	35,000.00	-35,000.00	0.0%
60.5 · Capital Outlay - New Shop P#2											
60.55 · Shop Fixtures	0.00	0.00	0.00	0.00	0.00	0.00	0.00	0.00	125,000.00	-125,000.00	0.0%
60.5 · Capital Outlay - New Shop P#2 - Other	0.00	4,914.30	23,446.00	114,622.00	173,701.55	201,184.70	720,202.64	1,238,071.19	6,095,365.00	-4,857,293.81	20.31%
Total 60.5 · Capital Outlay - New Shop P#2	0.00	4,914.30	23,446.00	114,622.00	173,701.55	201,184.70	720,202.64	1,238,071.19	6,220,365.00	-4,982,293.81	19.9%
60 · CAPITAL OUTLAY - Other	0.00	0.00	0.00	8,525.00	0.00	0.00	109,622.93	118,147.93	991,067.82	-872,919.89	11.92%
Total 60 · CAPITAL OUTLAY	551,342.24	816,694.93	1,000,015.04	555,658.40	865,654.71	921,289.33	1,127,472.79	5,838,127.44	14,068,085.74	-8,229,958.30	41.5%

South Walton County Mosquito Control District
Profit & Loss Budget vs. Actual
 October 2025 through April 2026

								TOTAL			
	<u>Oct 25</u>	<u>Nov 25</u>	<u>Dec 25</u>	<u>Jan 26</u>	<u>Feb 26</u>	<u>Mar 26</u>	<u>Apr 26</u>	<u>Oct '25 - Apr 26</u>	<u>Budget</u>	<u>\$ Over Budget</u>	<u>% of Budget</u>
66900 · Reconciliation Discrepancies	0.00	380.70	-380.70	0.00	0.00	0.00	0.00	0.00			
89 · CONTINGENCY	0.00	0.00	0.00	0.00	0.00	0.00	0.00	0.00	700,000.00	-700,000.00	0.0%
Total Expense	968,341.13	1,040,307.73	1,429,889.55	849,643.46	1,102,700.30	1,166,356.67	1,468,480.50	8,025,719.34	19,173,619.74	-11,147,900.40	41.86%
Net Income	<u>-827,882.54</u>	<u>945,907.08</u>	<u>4,235,117.02</u>	<u>-167,924.46</u>	<u>-737,009.88</u>	<u>-863,618.02</u>	<u>-1,022,345.87</u>	<u>1,562,243.33</u>	<u>-9,103,305.52</u>	<u>10,665,548.85</u>	<u>-17.16%</u>

South Walton County Mosquito Control District Profit & Loss Prev Year Comparison October 2025 through April 2026

	Oct '25 - Apr 26	Oct '24 - Apr 25	\$ Change	% Change
Income				
311.000 · AD VALOREM				
311.001 · Prior Year Taxes/Other	207.60	3,855.18	-3,647.58	-94.62%
311.000 · AD VALOREM - Other	9,229,706.43	8,129,720.90	1,099,985.53	13.53%
Total 311.000 · AD VALOREM	9,229,914.03	8,133,576.08	1,096,337.95	13.48%
361.000 · Interest income	357,814.25	451,434.19	-93,619.94	-20.74%
364.000 · Disposition of Fixed Assets	0.00	48,555.00	-48,555.00	-100.0%
369.000 · Other Misc Revenues	234.39	1,027.32	-792.93	-77.18%
Total Income	9,587,962.67	8,634,592.59	953,370.08	11.04%
Gross Profit	9,587,962.67	8,634,592.59	953,370.08	11.04%
Expense				
10 · PERSONAL SERVICES				
11 · Commissioner Salaries	8,307.90	8,307.90	0.00	0.0%
12 · Regular Salaries and wages				
16 · Compensated annual leave	45,429.82	61,294.21	-15,864.39	-25.88%
12 · Regular Salaries and wages - Other	663,594.52	670,911.43	-7,316.91	-1.09%
Total 12 · Regular Salaries and wages	709,024.34	732,205.64	-23,181.30	-3.17%
14 · Overtime				
18 · Compensated Compensatory Leave	0.00	612.63	-612.63	-100.0%
14 · Overtime - Other	1,170.88	364.66	806.22	221.09%
Total 14 · Overtime	1,170.88	977.29	193.59	19.81%
10 · PERSONAL SERVICES - Other	0.00	0.00	0.00	0.0%
Total 10 · PERSONAL SERVICES	718,503.12	741,490.83	-22,987.71	-3.1%
20 · PERSONAL SERVICES BENEFITS				
21 · FICA Taxes	51,959.91	53,000.95	-1,041.04	-1.96%
21.3 · Federal Unemployment	1,041.25	882.27	158.98	18.02%
22 · Retirement contributions				
22.2 · FRS paid by District	118,529.23	119,957.70	-1,428.47	-1.19%
Total 22 · Retirement contributions	118,529.23	119,957.70	-1,428.47	-1.19%
23 · Life and Health Insurance				

**South Walton County Mosquito Control District
Profit & Loss Prev Year Comparison
October 2025 through April 2026**

	<u>Oct '25 - Apr 26</u>	<u>Oct '24 - Apr 25</u>	<u>\$ Change</u>	<u>% Change</u>
23.1 · AFLAC	-353.66	-60.08	-293.58	-488.65%
23.3 · Vision	157.16	323.26	-166.10	-51.38%
23.4 · Life Insurance	4,315.98	4,950.73	-634.75	-12.82%
23.5 · STD/LTD	7,225.18	7,843.92	-618.74	-7.89%
23.55 · Dental	4,820.08	5,361.65	-541.57	-10.1%
23.7 · Supplement Insurance Program	150.00	1,250.00	-1,100.00	-88.0%
23.8 · BCBS of Florida - Medical Insur	258,358.39	255,534.81	2,823.58	1.11%
Total 23 · Life and Health Insurance	274,673.13	275,204.29	-531.16	-0.19%
25 · Unemployment Compensation	2,475.00	0.00	2,475.00	100.0%
26 · Other postemployment benefits				
26.2 · Jose Hernandez	11,015.72	10,239.84	775.88	7.58%
26.3 · Geraldine Via	10,694.02	10,023.54	670.48	6.69%
Total 26 · Other postemployment benefits	21,709.74	20,263.38	1,446.36	7.14%
Total 20 · PERSONAL SERVICES BENEFITS	470,388.26	469,308.59	1,079.67	0.23%
30 · OPERATING EXPENSES				
30.3 · Kristine Faulk	1,050.00	1,050.00	0.00	0.0%
30.5 · J Doug Liles	1,050.00	1,050.00	0.00	0.0%
30.6 · Stephen Young	1,050.00	1,050.00	0.00	0.0%
30.9 · Commissioner Monthly Stipend	225.00	0.00	225.00	100.0%
31 · Professional Services				
31.1 · Property Appraiser Fees	70,782.36	56,793.87	13,988.49	24.63%
31.2 · Tax Collector Fees	182,767.22	160,970.42	21,796.80	13.54%
31.4 · Medical Services	185.00	176.00	9.00	5.11%
Total 31 · Professional Services	253,734.58	217,940.29	35,794.29	16.42%
31.3 · Legal and Engineering Service				
31.6 · Legal Services	11,407.50	6,662.50	4,745.00	71.22%
31.8 · Albrecht Engineering	0.00	3,200.00	-3,200.00	-100.0%
31.3 · Legal and Engineering Service - Other	10.00	0.00	10.00	100.0%
Total 31.3 · Legal and Engineering Service	11,417.50	9,862.50	1,555.00	15.77%
32 · ACCOUNTING & AUDITING				

South Walton County Mosquito Control District Profit & Loss Prev Year Comparison October 2025 through April 2026

	Oct '25 - Apr 26	Oct '24 - Apr 25	\$ Change	% Change
32.1 · Audit	0.00	2,000.00	-2,000.00	-100.0%
Total 32 · ACCOUNTING & AUDITING	0.00	2,000.00	-2,000.00	-100.0%
34.00 · Other Services				
34.12 · Other services IT Hosting	69.57	0.00	69.57	100.0%
34.13 · NetData Consulting Services	14,244.00	16,072.00	-1,828.00	-11.37%
34.14 · LiveOak Fiber	845.00	0.00	845.00	100.0%
34.19 · IPS Contract Service Plan	330.00	0.00	330.00	100.0%
34.20 · UNIFIRST	2,796.41	4,327.06	-1,530.65	-35.37%
34.32 · EverOn System Montioring	3,185.74	0.00	3,185.74	100.0%
34.33 · Other Contractual Services	45,079.67	8,021.54	37,058.13	461.98%
34.00 · Other Services - Other	10,500.00	120.00	10,380.00	8,650.0%
Total 34.00 · Other Services	77,050.39	28,540.60	48,509.79	169.97%
Total 30 · OPERATING EXPENSES	345,577.47	261,493.39	84,084.08	32.16%
40 · TRAVEL & PER DIEM				
40.1 · PER DIEM OR MEALS	4,377.94	2,662.00	1,715.94	64.46%
40.2 · INCIDENTAL TRAVEL	152.72	0.00	152.72	100.0%
40.3 · PRIVIATE VEHICLES	1,480.20	813.40	666.80	81.98%
40.4 · Hotel	10,600.88	5,644.71	4,956.17	87.8%
Total 40 · TRAVEL & PER DIEM	16,611.74	9,120.11	7,491.63	82.14%
41 · COMMUNICATION SERVICES				
41.1 · Cellular Service	6,081.39	4,367.72	1,713.67	39.24%
41.2 · Office Phone & Internet	1,357.75	1,867.69	-509.94	-27.3%
Total 41 · COMMUNICATION SERVICES	7,439.14	6,235.41	1,203.73	19.31%
42 · FREIGHT SERVICES	1,163.93	1,003.09	160.84	16.03%
43 · UTILITY SERVICES				
43.02 · Water/Sewer	2,042.89	490.65	1,552.24	316.36%
43.03 · Electrical	10,331.38	5,543.02	4,788.36	86.39%
43.04 · GARBAGE SOLID WASTE SERVICES	753.20	792.88	-39.68	-5.01%
43.05 · Gas Service	1,800.08	0.00	1,800.08	100.0%
Total 43 · UTILITY SERVICES	14,927.55	6,826.55	8,101.00	118.67%

South Walton County Mosquito Control District Profit & Loss Prev Year Comparison October 2025 through April 2026

	Oct '25 - Apr 26	Oct '24 - Apr 25	\$ Change	% Change
44 · RENTALS & LEASES	1,332.99	10,893.17	-9,560.18	-87.76%
45 · INSURANCE				
45.3 · FLOOD INSURANCE	2,671.00	2,755.00	-84.00	-3.05%
45.5 · Workers Comp Insurance	16,696.96	30,421.33	-13,724.37	-45.11%
45.6 · General liability	75,345.00	60,441.00	14,904.00	24.66%
45.7 · Drone Insurance	0.00	22,406.77	-22,406.77	-100.0%
Total 45 · INSURANCE	94,712.96	116,024.10	-21,311.14	-18.37%
46 · REPAIR & MAINTENANCE SERVICES				
46.11 · Maint Bldg/Ground by others	0.00	4,500.00	-4,500.00	-100.0%
46.2 · Maintenance of Automotive Equip	68.31	1,293.07	-1,224.76	-94.72%
46.3 · Maintenance of Equipment Office				
46.31 · Software Maintenance Office Eq	31,702.41	14,154.56	17,547.85	123.97%
46.34 · NetData	6,322.00	0.00	6,322.00	100.0%
Total 46.3 · Maintenance of Equipment Office	38,024.41	14,154.56	23,869.85	168.64%
46.4 · Maint Other Equipment by others	652.42	730.44	-78.02	-10.68%
46.5 · Maint of Build & Grounds by Dis	844.85	207.31	637.54	307.53%
46.6 · Maint of equipment by DIdistrict	8,980.82	8,786.74	194.08	2.21%
46.61 · Maintenance material	0.00	509.81	-509.81	-100.0%
Total 46 · REPAIR & MAINTENANCE SERVICES	48,570.81	30,181.93	18,388.88	60.93%
47 · PRINTING & BINDING	235.94	120.00	115.94	96.62%
48 · PROMOTIONAL ACTIVITIES	1,704.65	5,080.88	-3,376.23	-66.45%
49 · OTHER CURRENT CHARGES				
49.1 · Other Government Agencies	701.60	761.03	-59.43	-7.81%
49.2 · advertising required by law	853.97	1,194.06	-340.09	-28.48%
49 · OTHER CURRENT CHARGES - Other	2,016.91	3,654.29	-1,637.38	-44.81%
Total 49 · OTHER CURRENT CHARGES	3,572.48	5,609.38	-2,036.90	-36.31%
50 · SUPPLIES/MATERIALS				
50.1 · Culligan	48.51	388.73	-340.22	-87.52%
50.3 · Employee Committee	4,352.97	3,973.52	379.45	9.55%
51 · Office Supplies	14,620.46	2,700.56	11,919.90	441.39%

South Walton County Mosquito Control District
Profit & Loss Prev Year Comparison
October 2025 through April 2026

	Oct '25 - Apr 26	Oct '24 - Apr 25	\$ Change	% Change
Total 50 · SUPPLIES/MATERIALS	19,021.94	7,062.81	11,959.13	169.33%
52 · Operating Supplies				
52.1 · Gasoline Oil Lubricant				
52.11 · Gasoline	13,145.25	14,388.29	-1,243.04	-8.64%
52.12 · Diesel				
52.121 · Diesel Exhaust Fluide DEF	0.00	240.34	-240.34	-100.0%
52.12 · Diesel - Other	8,367.46	6,284.39	2,083.07	33.15%
Total 52.12 · Diesel	8,367.46	6,524.73	1,842.73	28.24%
52.13 · Gasoline other than District	805.83	331.19	474.64	143.31%
52.1 · Gasoline Oil Lubricant - Other	630.82	0.00	630.82	100.0%
Total 52.1 · Gasoline Oil Lubricant	22,949.36	21,244.21	1,705.15	8.03%
52.2 · Chemicals Solvents Additives				
52.201 · PermaSease	0.00	32,919.75	-32,919.75	-100.0%
52.202 · Fyfanon	0.00	18,821.07	-18,821.07	-100.0%
52.204 · VMX Vectomax FG	66,444.00	64,447.00	1,997.00	3.1%
52.205 · Altosid P-35	65,760.00	84,210.00	-18,450.00	-21.91%
52.208 · Duplex-G Granular IGR	80,320.00	0.00	80,320.00	100.0%
52.21 · Natular XRT Tablet	0.00	5,174.40	-5,174.40	-100.0%
52.22 · VLX VCTOLEX WDG	1,755.20	6,433.32	-4,678.12	-72.72%
52.25 · Fourstar BTI CRG 35 lb	64,067.20	20,987.40	43,079.80	205.27%
52.26 · Altosid XR Slim	2,600.40	3,467.20	-866.80	-25.0%
52.27 · KONTROL 30-30	60,737.60	0.00	60,737.60	100.0%
52.28 · VectoBac WDG	0.00	1,112.92	-1,112.92	-100.0%
52.2 · Chemicals Solvents Additives - Other	23,100.00	0.00	23,100.00	100.0%
Total 52.2 · Chemicals Solvents Additives	364,784.40	237,573.06	127,211.34	53.55%
52.3 · Clothing and Wearing Apparel				
52.31 · uniforms	801.03	5,876.68	-5,075.65	-86.37%
52.32 · Boots	1,619.18	943.85	675.33	71.55%
52.33 · Misc. clothing	176.40	0.00	176.40	100.0%
Total 52.3 · Clothing and Wearing Apparel	2,596.61	6,820.53	-4,223.92	-61.93%

South Walton County Mosquito Control District Profit & Loss Prev Year Comparison October 2025 through April 2026

	Oct '25 - Apr 26	Oct '24 - Apr 25	\$ Change	% Change
52.4 · Misc Supplies & Incidentals				
52.41 · Yellow Fly	91.05	0.00	91.05	100.0%
52.411 · UAS - Drone Supplies	532.71	5.00	527.71	10,554.2%
52.42 · Mosquito	1,972.11	1,814.15	157.96	8.71%
52.43 · DITCHES	669.82	167.07	502.75	300.92%
52.44 · Safety	2,069.09	3,147.19	-1,078.10	-34.26%
52.45 · Shop	2,106.98	1,799.31	307.67	17.1%
52.47 · Chickens	2,768.03	2,504.75	263.28	10.51%
52.48 · Lab	7,559.54	325.58	7,233.96	2,221.87%
52.4 · Misc Supplies & Incidentals - Other	325.00	0.00	325.00	100.0%
Total 52.4 · Misc Supplies & Incidentals	18,094.33	9,763.05	8,331.28	85.34%
52.5 · Tool and small implements	451.48	0.00	451.48	100.0%
Total 52 · Operating Supplies	408,876.18	275,400.85	133,475.33	48.47%
54 · BOOKS, DUES & SUBSCRIPTIONS	19,733.37	12,193.75	7,539.62	61.83%
55 · TRAINING				
55.1 · Conferences	1,732.00	3,040.00	-1,308.00	-43.03%
55.2 · Classroom Education	1,851.11	1,705.00	146.11	8.57%
55.3 · Virtual Training	831.26	688.08	143.18	20.81%
55 · TRAINING - Other	10,805.00	0.00	10,805.00	100.0%
Total 55 · TRAINING	15,219.37	5,433.08	9,786.29	180.12%
60 · CAPITAL OUTLAY				
60.1 · DAG	8,145.50	18,843.25	-10,697.75	-56.77%
60.15 · DAG - Phase II	76,953.70	631,384.49	-554,430.79	-87.81%
60.2 · Capital Outlay – New Admin				
60.25 · New Admin Bldg Furn/Fix	2,300.00	116,348.03	-114,048.03	-98.02%
60.2 · Capital Outlay – New Admin - Other	814,713.19	2,754,911.07	-1,940,197.88	-70.43%
Total 60.2 · Capital Outlay – New Admin	817,013.19	2,871,259.10	-2,054,245.91	-71.55%
60.3 · Capital Outlay - New ParkingP#2	3,579,795.93	36,962.28	3,542,833.65	9,585.0%
60.5 · Capital Outlay - New Shop P#2	1,238,071.19	0.00	1,238,071.19	100.0%
60 · CAPITAL OUTLAY - Other	118,147.93	29,322.15	88,825.78	302.93%

South Walton County Mosquito Control District
Profit & Loss Prev Year Comparison
October 2025 through April 2026

	<u>Oct '25 - Apr 26</u>	<u>Oct '24 - Apr 25</u>	<u>\$ Change</u>	<u>% Change</u>
Total 60 · CAPITAL OUTLAY	5,838,127.44	3,587,771.27	2,250,356.17	62.72%
66900 · Reconciliation Discrepancies	0.00	0.00	0.00	0.0%
Total Expense	8,025,719.34	5,551,249.19	2,474,470.15	44.58%
Net Income	<u>1,562,243.33</u>	<u>3,083,343.40</u>	<u>-1,521,100.07</u>	<u>-49.33%</u>

South Walton County Mosquito Control District Expenses by Vendor Detail

April 2026

Account	Type	Date	Num	Memo	Split	Debit	Credit	Balance
ADVANCE AUTO PARTS								
46.6 · Maint of equip...	Credit Card Ch...	04/22/2021	78186112...		229.008 · Ameris Cred...	42.55		42.55
Total ADVANCE AUTO PARTS						42.55	0.00	42.55
AFLAC								
23.1 · AFLAC	Check	04/01/2021	ACH	317586	102.004 · Ameris Chec...	988.40		988.40
Total AFLAC						988.40	0.00	988.40
AIRGAS								
52.45 · Shop	Credit Card Ch...	04/28/2021	148164510	Hose & Spool Copper	229.008 · Ameris Cred...	103.76		103.76
Total AIRGAS						103.76	0.00	103.76
AMAZON								
52.48 · Lab	Credit Card Ch...	04/02/2021	1079427		229.009 · Ameris Cred...	41.07		41.07
46.5 · Maint of Build...	Credit Card Ch...	04/02/2021	1752229		229.009 · Ameris Cred...	49.99		91.06
52.45 · Shop	Credit Card Ch...	04/06/2021	7117028	Tint for Energreen	229.009 · Ameris Cred...	82.22		173.28
48 · PROMOTIONA...	Credit Card Ch...	04/07/2021	9133808	Colored Paper	229.009 · Ameris Cred...	22.12		195.40
51 · Office Supplies	Credit Card Ch...	04/07/2021	6473013		229.009 · Ameris Cred...	6.99		202.39
52.48 · Lab	Credit Card Ch...	04/07/2021	6473013		229.009 · Ameris Cred...	17.09		219.48
52.48 · Lab	Credit Card Ch...	04/07/2021	4004266		229.009 · Ameris Cred...	6.74		226.22
51 · Office Supplies	Credit Card Ch...	04/07/2021	6988255	2 keyboards	229.009 · Ameris Cred...	47.98		274.20
51 · Office Supplies	Credit Card Cre...	04/08/2021	4346669		229.009 · Ameris Cred...		62.99	211.21
51 · Office Supplies	Credit Card Ch...	04/09/2021	4032239	ink for stamp	229.009 · Ameris Cred...	6.99		218.20
52.48 · Lab	Credit Card Ch...	04/09/2021	3315458	quick connect drip irr...	229.009 · Ameris Cred...	9.99		228.19
51 · Office Supplies	Credit Card Ch...	04/13/2021	1087445	Cell phone cases an...	229.009 · Ameris Cred...	46.02		274.21
48 · PROMOTIONA...	Credit Card Ch...	04/13/2021	1614604	spinner and bubbles	229.009 · Ameris Cred...	27.78		301.99
52.5 · Tool and sma...	Credit Card Ch...	04/14/2021	6384214	Seal adapter set for ...	229.009 · Ameris Cred...	66.49		368.48
52.48 · Lab	Credit Card Ch...	04/14/2021	6954624	drip irrigation tubing	229.009 · Ameris Cred...	10.48		378.96
51 · Office Supplies	Credit Card Ch...	04/16/2021	3705013	Toner Laser Printer	229.009 · Ameris Cred...	511.89		890.85
48 · PROMOTIONA...	Credit Card Ch...	04/16/2021	7477042	Glassine paper bags ...	229.009 · Ameris Cred...	7.48		898.33
51 · Office Supplies	Credit Card Cre...	04/20/2021	4321829	Return Toner laser	229.009 · Ameris Cred...		88.39	809.94
52.48 · Lab	Credit Card Ch...	04/20/2021	1954603	magnetic boards	229.009 · Ameris Cred...	53.22		863.16
52.42 · Mosquito	Credit Card Ch...	04/20/2021	4230656	Batteries for traps	229.009 · Ameris Cred...	539.96		1,403.12
52.48 · Lab	Credit Card Ch...	04/21/2021	9008203	Test Tube Clamps	229.009 · Ameris Cred...	9.99		1,413.11
51 · Office Supplies	Credit Card Ch...	04/22/2021	0386652	Mesh organizer	229.009 · Ameris Cred...	14.61		1,427.72
51 · Office Supplies	Credit Card Ch...	04/22/2021	0386652	Retractable Gel Pans	229.009 · Ameris Cred...	13.49		1,441.21
51 · Office Supplies	Credit Card Ch...	04/22/2021	0386652	Cell Phone protector	229.009 · Ameris Cred...	6.96		1,448.17
52.48 · Lab	Credit Card Ch...	04/22/2021	3104264	Disposable pipettes	229.009 · Ameris Cred...	26.99		1,475.16
51 · Office Supplies	Credit Card Ch...	04/22/2021	2141029	Paper	229.009 · Ameris Cred...	102.54		1,577.70
52.48 · Lab	Credit Card Ch...	04/22/2021	7479462	Electrical outlet covers	229.009 · Ameris Cred...	5.76		1,583.46
51 · Office Supplies	Credit Card Ch...	04/22/2021	0215437	Board room extensio...	229.009 · Ameris Cred...	297.00		1,880.46
52.44 · Safety	Credit Card Ch...	04/26/2021	6977012	Rubber Gloves	229.009 · Ameris Cred...	129.99		2,010.45
51 · Office Supplies	Credit Card Cre...	04/28/2021	0386652	Mesh tray returned	229.009 · Ameris Cred...		14.61	1,995.84
51 · Office Supplies	Credit Card Cre...	04/28/2021	0386652		229.009 · Ameris Cred...		6.96	1,988.88
48 · PROMOTIONA...	Credit Card Ch...	04/29/2021	2864222	Card Stock	229.009 · Ameris Cred...	22.80		2,011.68
46.6 · Maint of equip...	Credit Card Ch...	04/29/2021	2214626	#553	229.009 · Ameris Cred...	77.98		2,089.66
51 · Office Supplies	Credit Card Ch...	04/29/2021	0781012		229.009 · Ameris Cred...	24.55		2,114.21
48 · PROMOTIONA...	Credit Card Ch...	04/29/2021	8317831	Metal Brads	229.009 · Ameris Cred...	7.99		2,122.20
52.411 · UAS - Dron...	Credit Card Ch...	04/30/2021	5401066		229.009 · Ameris Cred...	5.98		2,128.18
52.48 · Lab	Credit Card Ch...	04/30/2021	0470615		229.009 · Ameris Cred...	21.24		2,149.42
Total AMAZON						2,322.37	172.95	2,149.42
ANIXTER INC								
60.3 · Capital Outlay...	Bill	04/13/2021	SE45451...	FM-004	202.000 · Accounts Pa...	11,761.37		11,761.37
60.3 · Capital Outlay...	Credit	04/23/2021	SE45472...	FM-004	202.000 · Accounts Pa...		139.77	11,621.60
Total ANIXTER INC						11,761.37	139.77	11,621.60
BEARD EQUIPMENT/POWERPLAN								
46.6 · Maint of equip...	Bill	04/09/2021	2283061	572 Energreen Alpha	202.000 · Accounts Pa...	66.22		66.22
46.6 · Maint of equip...	Bill	04/27/2021	2291232	Aspen Energreen	202.000 · Accounts Pa...	1,455.54		1,521.76
Total BEARD EQUIPMENT/POWERPLAN						1,521.76	0.00	1,521.76
BLUE CROSS BLUE SHIELD								
23.8 · BCBS of Flori...	Check	04/01/2021	ACH	14006	102.004 · Ameris Chec...	7,223.34		7,223.34
23.8 · BCBS of Flori...	Check	04/01/2021	ACH	14001	102.004 · Ameris Chec...	14,505.54		21,728.88
23.8 · BCBS of Flori...	Check	04/01/2021	ACH	14003	102.004 · Ameris Chec...	17,278.87		39,007.75
26.2 · Jose Hernand...	Check	04/01/2021	ACH	Jose Retiree	102.004 · Ameris Chec...	1,344.66		40,352.41
26.3 · Geraldine Via	Check	04/01/2021	ACH	Geraldine Retiree	102.004 · Ameris Chec...	1,344.66		41,697.07
Total BLUE CROSS BLUE SHIELD						41,697.07	0.00	41,697.07

South Walton County Mosquito Control District Expenses by Vendor Detail

April 2026

Account	Type	Date	Num	Memo	Split	Debit	Credit	Balance
BUILDERS FIRST SOURCE								
60.3 · Capital Outlay...	Bill	04/03/2021	92038255	PG-012	202.000 · Accounts Pa...	3,212.27		3,212.27
60.3 · Capital Outlay...	Credit	04/03/2021	93882158	PG-012	202.000 · Accounts Pa...		3,212.27	0.00
60.3 · Capital Outlay...	Credit	04/03/2021	93703511	PG-012	202.000 · Accounts Pa...		747.76	-747.76
60.3 · Capital Outlay...	Bill	04/03/2021	93882189	PG-012	202.000 · Accounts Pa...	747.76		0.00
60.3 · Capital Outlay...	Bill	04/03/2021	93882280	PG-012	202.000 · Accounts Pa...	744.00		744.00
Total BUILDERS FIRST SOURCE						4,704.03	3,960.03	744.00
CHELCO								
43.03 · Electrical	Check	04/30/2021	ach	700109304	102.004 · Ameris Chec...	1,798.56		1,798.56
Total CHELCO						1,798.56	0.00	1,798.56
CLARKE								
52.2 · Chemicals So...	Bill	04/13/2021	005115621		202.000 · Accounts Pa...	23,100.00		23,100.00
52.42 · Mosquito	Bill	04/22/2021	005115791		202.000 · Accounts Pa...	136.28		23,236.28
52.42 · Mosquito	Credit	04/29/2021	005115907	BG Traps	202.000 · Accounts Pa...		158.29	23,077.99
Total CLARKE						23,236.28	158.29	23,077.99
COASTAL ICE DISTRIBUTORS								
52.42 · Mosquito	Credit Card Ch...	04/08/2021	128228		229.008 · Ameris Cred...	132.75		132.75
Total COASTAL ICE DISTRIBUTORS						132.75	0.00	132.75
CONSOLIDATED ACE								
52.47 · Chickens	Bill	04/18/2021	806655		202.000 · Accounts Pa...	92.40		92.40
Total CONSOLIDATED ACE						92.40	0.00	92.40
DAG ARCHITECTS INC								
60.15 · DAG - Phas...	Bill	04/30/2021	24079-0426	Construction Admini...	202.000 · Accounts Pa...	8,975.00		8,975.00
60.15 · DAG - Phas...	Bill	04/30/2021	24079-0426	Additional Services - ...	202.000 · Accounts Pa...	11,340.00		20,315.00
Total DAG ARCHITECTS INC						20,315.00	0.00	20,315.00
DEFUNIAK HERALD								
54 · BOOKS, DUES...	Bill	04/09/2021	2026 Sub...		202.000 · Accounts Pa...	39.00		39.00
49.2 · advertising re...	Bill	04/15/2021	9129Z		202.000 · Accounts Pa...	13.50		52.50
Total DEFUNIAK HERALD						52.50	0.00	52.50
DREXEL METALS								
60.5 · Capital Outlay...	Bill	04/03/2021	96593788	FM-012	202.000 · Accounts Pa...	19,261.80		19,261.80
60.5 · Capital Outlay...	Bill	04/09/2021	96602625	FM-012	202.000 · Accounts Pa...	101,922.91		121,184.71
Total DREXEL METALS						121,184.71	0.00	121,184.71
Duncan Parnell								
60 · CAPITAL OUT...	Check	04/22/2021	ACH	Lidar Drone	102.060 · Capital City ...	96,845.00		96,845.00
Total Duncan Parnell						96,845.00	0.00	96,845.00
EGIS								
45.5 · Workers Com...	Deposit	04/01/2021	4036	Premium audit refund	102.060 · Capital City ...		8,623.82	-8,623.82
Total EGIS						0.00	8,623.82	-8,623.82
Fastest Labs								
31.4 · Medical Servi...	Credit Card Ch...	04/07/2021	2191	Loren - Drug Screen	229.008 · Ameris Cred...	49.00		49.00
Total Fastest Labs						49.00	0.00	49.00
FEDEX								
42 · FREIGHT SER...	Check	04/09/2021	ACH	818742057112	102.004 · Ameris Chec...	81.54		81.54
42 · FREIGHT SER...	Check	04/16/2021	ACH	187759331	102.004 · Ameris Chec...	53.47		135.01
42 · FREIGHT SER...	Check	04/23/2021	ACH	187759331	102.004 · Ameris Chec...	131.28		266.29
42 · FREIGHT SER...	Check	04/30/2021	ach	187759331	102.004 · Ameris Chec...	54.50		320.79
Total FEDEX						320.79	0.00	320.79
FL HWY SAFETY & MOTOR VEHICLES								
49.1 · Other Govern...	Bill	04/21/2021	Annual C...	Driver's License Check	202.000 · Accounts Pa...	208.00		208.00
Total FL HWY SAFETY & MOTOR VEHICLES						208.00	0.00	208.00
Florida Institute of Government								
55.3 · Virtual Training	Credit Card Ch...	04/07/2021	1609809	Public Records Mgmt	229.008 · Ameris Cred...	150.00		150.00
Total Florida Institute of Government						150.00	0.00	150.00

South Walton County Mosquito Control District Expenses by Vendor Detail April 2026

Account	Type	Date	Num	Memo	Split	Debit	Credit	Balance
FRANKS CASH & CARRY								
46.6 · Maint of equip...	Credit Card Ch...	04/30/2021	2604-113...	JD Tractor #494	229.008 · Ameris Cred...	6.99		6.99
Total FRANKS CASH & CARRY						6.99	0.00	6.99
GO DADDY								
34.12 · Other servic...	Check	04/30/2021	ACH		102.004 · Ameris Chec...	23.19		23.19
Total GO DADDY						23.19	0.00	23.19
Hemotek Ltd								
52.48 · Lab	Check	04/22/2021	ACH		102.060 · Capital City ...	2,294.72		2,294.72
Total Hemotek Ltd						2,294.72	0.00	2,294.72
HILTON HOTELS & RESORTS								
40.4 · Hotel	Credit Card Ch...	04/12/2021	97905458	Orlando FGFOA	229.002 · Ameris Cred...	567.00		567.00
Total HILTON HOTELS & RESORTS						567.00	0.00	567.00
IDEAL POULTRY								
52.47 · Chickens	Credit Card Ch...	04/13/2021	875892-1	Golden Star Females	229.008 · Ameris Cred...	371.50		371.50
Total IDEAL POULTRY						371.50	0.00	371.50
INDEED								
49.2 · advertising re...	Credit Card Ch...	04/02/2021	02461857		229.010 · Ameris Cred...	292.50		292.50
Total INDEED						292.50	0.00	292.50
INTUIT								
46.31 · Software Ma...	Credit Card Ch...	04/02/2021	14810451...		229.010 · Ameris Cred...	188.00		188.00
46.31 · Software Ma...	Credit Card Ch...	04/05/2021	P1-11395...		229.010 · Ameris Cred...	69.50		257.50
51 · Office Supplies	Check	04/13/2021	ACH	Checks	102.060 · Capital City ...	345.37		602.87
Total INTUIT						602.87	0.00	602.87
IPS								
46.4 · Maint Other E...	Bill	04/29/2021	26356910	Generator - Admin Bl...	202.000 · Accounts Pa...	590.85		590.85
Total IPS						590.85	0.00	590.85
LOWE'S								
46.6 · Maint of equip...	Credit Card Ch...	04/28/2021	41593790	Aspen Energreen	229.008 · Ameris Cred...	9.67		9.67
Total LOWE'S						9.67	0.00	9.67
MAYER ELECTRIC								
60.5 · Capital Outlay...	Bill	04/14/2021	35942790	FM-003	202.000 · Accounts Pa...	2,021.95		2,021.95
60.5 · Capital Outlay...	Bill	04/15/2021	35945749	FM-003	202.000 · Accounts Pa...	23,109.46		25,131.41
60.5 · Capital Outlay...	Bill	04/23/2021	35965412	FM-003	202.000 · Accounts Pa...	5,937.78		31,069.19
Total MAYER ELECTRIC						31,069.19	0.00	31,069.19
MEHLHORN'S MINI MART								
52.47 · Chickens	Bill	04/13/2021	FX4EJ2B...		202.000 · Accounts Pa...	32.18		32.18
52.43 · DITCHES	Bill	04/30/2021	ZD23Z30...	Hay Bales (9)	202.000 · Accounts Pa...	107.91		140.09
Total MEHLHORN'S MINI MART						140.09	0.00	140.09
Michael McManus								
31.3 · Legal and En...	Bill	04/09/2021	Easement	Easement Parcel 44 ...	202.000 · Accounts Pa...	10.00		10.00
Total Michael McManus						10.00	0.00	10.00
Murphy USA								
52.13 · Gasoline oth...	Credit Card Ch...	04/15/2021	034107	Orlando FAFOGA	229.002 · Ameris Cred...	34.00		34.00
Total Murphy USA						34.00	0.00	34.00
NETDATA CONSULTING SERVICES								
51 · Office Supplies	Credit Card Ch...	04/01/2021	50464	HP Printer	229.008 · Ameris Cred...	525.00		525.00
60 · CAPITAL OUT...	Check	04/09/2021	ACH	Laptop SN SA0034H...	102.004 · Ameris Chec...	1,032.65		1,557.65
34.13 · NetData Co...	Check	04/21/2021	ACH		102.004 · Ameris Chec...	2,374.00		3,931.65
Total NETDATA CONSULTING SERVICES						3,931.65	0.00	3,931.65
O'REILLY								
46.6 · Maint of equip...	Bill	04/27/2021	5340-444...	Oil filters	202.000 · Accounts Pa...	34.62		34.62
Total O'REILLY						34.62	0.00	34.62

South Walton County Mosquito Control District Expenses by Vendor Detail April 2026

Account	Type	Date	Num	Memo	Split	Debit	Credit	Balance
OKALOOSA GAS DISTRICT								
43.05 · Gas Service	Check	04/09/2021	ACH		102.004 · Ameris Chec...	52.01		52.01
Total OKALOOSA GAS DISTRICT						52.01	0.00	52.01
OLDCASTLE APG, INC								
60.3 · Capital Outlay...	Bill	04/08/2021	30001709...	PG-006	202.000 · Accounts Pa...	3,258.12		3,258.12
60.3 · Capital Outlay...	Bill	04/09/2021	30001775...	PG-006	202.000 · Accounts Pa...	3,200.88		6,459.00
60.3 · Capital Outlay...	Bill	04/14/2021	30001875...	PG-006	202.000 · Accounts Pa...	3,262.56		9,721.56
Total OLDCASTLE APG, INC						9,721.56	0.00	9,721.56
PRO AV								
34.33 · Other Contr...	Bill	04/30/2021	2033	Additional AV work i...	202.000 · Accounts Pa...	3,745.48		3,745.48
Total PRO AV						3,745.48	0.00	3,745.48
PUBLIX								
48 · PROMOTIONA...	Credit Card Ch...	04/20/2021	524554	Mosquito Week Treats	229.008 · Ameris Cred...	16.47		16.47
Total PUBLIX						16.47	0.00	16.47
REGIONAL UTILITIES								
43.02 · Water/Sewer	Check	04/02/2021	ACH		102.004 · Ameris Chec...	278.73		278.73
Total REGIONAL UTILITIES						278.73	0.00	278.73
RETIF								
52.11 · Gasoline	Check	04/09/2021	ACH		102.004 · Ameris Chec...	1,834.78		1,834.78
52.11 · Gasoline	Check	04/30/2021	ACH		102.004 · Ameris Chec...	1,375.28		3,210.06
52.12 · Diesel	Check	04/30/2021	ACH		102.004 · Ameris Chec...	1,536.00		4,746.06
Total RETIF						4,746.06	0.00	4,746.06
RHONDA SKIPPER								
311.000 · AD VALO...	Deposit	04/17/2021	ACH	Department of Envir...	102.005 · Ameris Mon...		5,405.63	-5,405.63
361.000 · Interest in...	Deposit	04/28/2021		Interest Distribution ...	102.005 · Ameris Mon...		3,292.84	-8,698.47
311.000 · AD VALO...	Deposit	04/30/2021		2025 Tax Roll Distrib...	102.005 · Ameris Mon...		395,633.27	-404,331.74
31.2 · Tax Collector ...	Deposit	04/30/2021		2025 Tax Roll Distrib...	102.005 · Ameris Mon...	7,912.67		-396,419.07
Total RHONDA SKIPPER						7,912.67	404,331.74	-396,419.07
SHELL GAS STATION								
52.13 · Gasoline oth...	Credit Card Ch...	04/15/2021	9045188	Orlando - FGFOA	229.002 · Ameris Cred...	39.60		39.60
Total SHELL GAS STATION						39.60	0.00	39.60
Southern Coast Forklift								
60 · CAPITAL OUT...	Check	04/02/2021	ACH	2018 Caterpillar Fork...	102.004 · Ameris Chec...	11,745.28		11,745.28
Total Southern Coast Forklift						11,745.28	0.00	11,745.28
SOUTHERN MAID ENTERPRISES								
34.00 · Other Servic...	Bill	04/01/2021	3485		202.000 · Accounts Pa...	2,100.00		2,100.00
34.00 · Other Servic...	Bill	04/30/2021	3486		202.000 · Accounts Pa...	2,100.00		4,200.00
Total SOUTHERN MAID ENTERPRISES						4,200.00	0.00	4,200.00
SRM CONCRETE								
60.5 · Capital Outlay...	Bill	04/01/2021	10109340...	FM-008	202.000 · Accounts Pa...	21,184.00		21,184.00
60.5 · Capital Outlay...	Bill	04/10/2021	10109347...	FM-008	202.000 · Accounts Pa...	10,174.00		31,358.00
60.5 · Capital Outlay...	Bill	04/17/2021	10109471...	FM-008	202.000 · Accounts Pa...	1,710.00		33,068.00
60.5 · Capital Outlay...	Bill	04/27/2021	10109522...	FM-008	202.000 · Accounts Pa...	2,784.00		35,852.00
Total SRM CONCRETE						35,852.00	0.00	35,852.00
STANDARD INSURANCE								
23.4 · Life Insurance	Check	04/02/2021	ACH	District Life	102.004 · Ameris Chec...	291.74		291.74
23.4 · Life Insurance	Check	04/02/2021	ACH	Add'l Life	102.004 · Ameris Chec...	369.05		660.79
23.5 · STD/LTD	Check	04/02/2021	ACH	STD	102.004 · Ameris Chec...	807.80		1,468.59
23.5 · STD/LTD	Check	04/02/2021	ACH	LTD	102.004 · Ameris Chec...	860.68		2,329.27
23.55 · Dental	Check	04/03/2021	ACH		102.004 · Ameris Chec...	1,119.72		3,448.99
23.3 · Vision	Check	04/03/2021	ACH		102.004 · Ameris Chec...	310.20		3,759.19
Total STANDARD INSURANCE						3,759.19	0.00	3,759.19
T-MOBILE USA								
41.1 · Cellular Service	Check	04/29/2021	ACH		102.060 · Capital City ...	772.01		772.01
41.2 · Office Phone ...	Check	04/29/2021	ACH		102.060 · Capital City ...	240.28		1,012.29
Total T-MOBILE USA						1,012.29	0.00	1,012.29

South Walton County Mosquito Control District Expenses by Vendor Detail

April 2026

Account	Type	Date	Num	Memo	Split	Debit	Credit	Balance
THOMPSON CAT								
46.6 · Maint of equip...	Bill	04/01/2021	SPI01820...		202.000 · Accounts Pa...	264.78		264.78
Total THOMPSON CAT						264.78	0.00	264.78
Threaded Fasteners Inc								
60.5 · Capital Outlay...	Bill	04/08/2021	4121773	FM-014	202.000 · Accounts Pa...	286.65		286.65
60.5 · Capital Outlay...	Bill	04/08/2021	4119372	FM-014	202.000 · Accounts Pa...	6,196.25		6,482.90
Total Threaded Fasteners Inc						6,482.90	0.00	6,482.90
TRANE US								
60.5 · Capital Outlay...	Bill	04/09/2021	990431711	FM-009	202.000 · Accounts Pa...	5,705.41		5,705.41
60.5 · Capital Outlay...	Bill	04/14/2021	990470500	FM-009	202.000 · Accounts Pa...	64,033.95		69,739.36
Total TRANE US						69,739.36	0.00	69,739.36
UNIFIRST								
34.20 · UNIFIRST	Bill	04/01/2021	20401235...		202.000 · Accounts Pa...	97.23		97.23
34.20 · UNIFIRST	Bill	04/08/2021	20401241...		202.000 · Accounts Pa...	97.23		194.46
34.20 · UNIFIRST	Bill	04/15/2021	20401246...		202.000 · Accounts Pa...	97.23		291.69
34.20 · UNIFIRST	Bill	04/22/2021	20401252...		202.000 · Accounts Pa...	97.23		388.92
34.20 · UNIFIRST	Bill	04/29/2021	20401258...		202.000 · Accounts Pa...	95.50		484.42
Total UNIFIRST						484.42	0.00	484.42
United States Plastic Corporation								
52.48 · Lab	Credit Card Ch...	04/01/2021	7882024		229.008 · Ameris Cred...	31.18		31.18
Total United States Plastic Corporation						31.18	0.00	31.18
USPS								
49.1 · Other Govern...	Credit Card Ch...	04/21/2021	178		229.008 · Ameris Cred...	16.56		16.56
49.1 · Other Govern...	Credit Card Ch...	04/23/2021	256	MVR Reports	229.008 · Ameris Cred...	3.00		19.56
Total USPS						19.56	0.00	19.56
VESERIS								
52.27 · KONTROL 3...	Bill	04/01/2021	105531846	PO 26-12	202.000 · Accounts Pa...	60,737.60		60,737.60
52.205 · Altosid P-35	Bill	04/29/2021	CINV105...	PO 26-15	202.000 · Accounts Pa...	33,360.00		94,097.60
Total VESERIS						94,097.60	0.00	94,097.60
VISTAPRINT								
51 · Office Supplies	Credit Card Ch...	04/14/2021	VP-3QW...	sign stamp DD	229.010 · Ameris Cred...	22.98		22.98
Total VISTAPRINT						22.98	0.00	22.98
WALMART SUPERSTORE								
52.48 · Lab	Credit Card Ch...	04/07/2021	65627166	Jars	229.008 · Ameris Cred...	11.27		11.27
Total WALMART SUPERSTORE						11.27	0.00	11.27
WALTON COUNTY PROPERTY APPRIASER								
31.1 · Property Appr...	Bill	04/01/2021	3rd Quarter		202.000 · Accounts Pa...	23,594.12		23,594.12
Total WALTON COUNTY PROPERTY APPRIASER						23,594.12	0.00	23,594.12
WASTE MANAGEMENT								
43.04 · GARBAGE ...	Check	04/15/2021	ACH		102.004 · Ameris Chec...	107.60		107.60
Total WASTE MANAGEMENT						107.60	0.00	107.60
WHARTON-SMITH, INC								
60.3 · Capital Outlay...	Check	04/27/2021	ACH	BP 3A Cast in Place ...	102.004 · Ameris Chec...	6,239.74		6,239.74
60.3 · Capital Outlay...	Check	04/27/2021	ACH	BP 7A Metal Roofing	102.004 · Ameris Chec...	8,142.00		14,381.74
60.3 · Capital Outlay...	Check	04/27/2021	ACH	BP 8A Doors and Ha...	102.004 · Ameris Chec...	6,470.11		20,851.85
60.3 · Capital Outlay...	Check	04/27/2021	ACH	BP 9C Painting	102.004 · Ameris Chec...	51,130.22		71,982.07
60.3 · Capital Outlay...	Check	04/27/2021	ACH	BP 21A Fire Protection	102.004 · Ameris Chec...	24,275.00		96,257.07
60.3 · Capital Outlay...	Check	04/27/2021	ACH	BP 22A Plumbing	102.004 · Ameris Chec...	12,810.63		109,067.70
60.3 · Capital Outlay...	Check	04/27/2021	ACH	BP 23A HVAC	102.004 · Ameris Chec...	9,047.67		118,115.37
60.3 · Capital Outlay...	Check	04/27/2021	ACH	BP 26A Electrical Sy...	102.004 · Ameris Chec...	19,254.76		137,370.13
60.3 · Capital Outlay...	Check	04/27/2021	ACH	BP 31A Earthword, ...	102.004 · Ameris Chec...	69,350.00		206,720.13
60.3 · Capital Outlay...	Check	04/27/2021	ACH	Metal Building (Chick...	102.004 · Ameris Chec...	7,000.00		213,720.13
60.5 · Capital Outlay...	Check	04/27/2021	ACH	BP 3A Cast In Place ...	102.004 · Ameris Chec...	100,650.00		314,370.13
60.5 · Capital Outlay...	Check	04/27/2021	ACH	BP 4A Masonry	102.004 · Ameris Chec...	89,500.00		403,870.13
60.5 · Capital Outlay...	Check	04/27/2021	ACH	BP 10A Specialties	102.004 · Ameris Chec...	6,362.98		410,233.11
60.5 · Capital Outlay...	Check	04/27/2021	ACH	BP 22A Plumbing	102.004 · Ameris Chec...	11,800.00		422,033.11
60.5 · Capital Outlay...	Check	04/27/2021	ACH	BP 26A Electrical Sy...	102.004 · Ameris Chec...	27,840.00		449,873.11
60.5 · Capital Outlay...	Check	04/27/2021	ACH	BP 32A :Landscapin...	102.004 · Ameris Chec...	56,300.00		506,173.11
60.5 · Capital Outlay...	Check	04/27/2021	ACH	LS GC's & GR's	102.004 · Ameris Chec...	91,000.00		597,173.11
60.5 · Capital Outlay...	Check	04/27/2021	ACH	IT Software	102.004 · Ameris Chec...	1,239.00		598,412.11

**South Walton County Mosquito Control District
Expenses by Vendor Detail
April 2026**

Account	Type	Date	Num	Memo	Split	Debit	Credit	Balance
60.5 · Capital Outlay...	Check	04/27/2021	ACH	Permits	102.004 · Ameris Chec...	11.39		598,423.50
60.5 · Capital Outlay...	Check	04/27/2021	ACH	P&P Bond	102.004 · Ameris Chec...	20,345.00		618,768.50
60.5 · Capital Outlay...	Check	04/27/2021	ACH	CM Fee	102.004 · Ameris Chec...	50,826.11		669,594.61
60.2 · Capital Outlay...	Check	04/27/2021	ACH	GCs & Grs	102.004 · Ameris Chec...		148.91	669,445.70
60.2 · Capital Outlay...	Check	04/27/2021	ACH	BP 3A CIP Concrete	102.004 · Ameris Chec...	6,522.18		675,967.88
60.2 · Capital Outlay...	Check	04/27/2021	ACH	BP4A Masonry	102.004 · Ameris Chec...	1,668.10		677,635.98
60.2 · Capital Outlay...	Check	04/27/2021	ACH	BP 8A Storefront	102.004 · Ameris Chec...	148.91		677,784.89
60.2 · Capital Outlay...	Check	04/27/2021	ACH	BP 8B Doors & Hard...	102.004 · Ameris Chec...	2,700.84		680,485.73
60.2 · Capital Outlay...	Check	04/27/2021	ACH	BP 9B Flooring	102.004 · Ameris Chec...	4,304.25		684,789.98
60.2 · Capital Outlay...	Check	04/27/2021	ACH	BP 21A Fire Protection	102.004 · Ameris Chec...	132.82		684,922.80
60.2 · Capital Outlay...	Check	04/27/2021	ACH	BP 26A Electrical Sy...	102.004 · Ameris Chec...	1,686.05		686,608.85
60.2 · Capital Outlay...	Check	04/27/2021	ACH	BP 27B Telecom & I...	102.004 · Ameris Chec...	5,700.01		692,308.86
60.2 · Capital Outlay...	Check	04/27/2021	ACH	BP 33A Landscaping	102.004 · Ameris Chec...	15,000.00		707,308.86
60.2 · Capital Outlay...	Check	04/27/2021	ACH	Permits	102.004 · Ameris Chec...		4,278.87	703,029.99
60.2 · Capital Outlay...	Check	04/27/2021	ACH	Builder's Risk Insura...	102.004 · Ameris Chec...		4,230.45	698,799.54
60.15 · DAG - Phas...	Check	04/27/2021	ACH	P&P Bond	102.004 · Ameris Chec...		8,139.00	690,660.54
60.2 · Capital Outlay...	Check	04/27/2021	ACH	CM Fees	102.004 · Ameris Chec...	18,159.00		708,819.54
Total WHARTON-SMITH, INC						725,616.77	16,797.23	708,819.54
Woerner Landscape								
52.43 · DITCHES	Credit Card Ch...	04/29/2021	419672	Turf	229.010 · Ameris Cred...	420.00		420.00
Total Woerner Landscape						420.00	0.00	420.00
WOODLANE CABINET COMPANY								
60.25 · New Admin ...	Bill	04/01/2021	ESTIMAT...	1/2 DEPOSIT OF LA...	202.000 · Accounts Pa...	2,300.00		2,300.00
Total WOODLANE CABINET COMPANY						2,300.00	0.00	2,300.00
XEROX CORPORATION								
34.33 · Other Contr...	Bill	04/01/2021	025353362		202.000 · Accounts Pa...	150.83		150.83
34.33 · Other Contr...	Bill	04/01/2021	025353363		202.000 · Accounts Pa...	48.26		199.09
Total XEROX CORPORATION						199.09	0.00	199.09
No name								
361.000 · Interest in...	Deposit	04/30/2021		Interest	102.008 · FL FIT		41,802.89	-41,802.89
Total no name						0.00	41,802.89	-41,802.89
TOTAL						1,373,978.11	475,986.72	897,991.39

LEGAL REPORT





304 Magnolia Avenue
Panama City, FL 32401
T (850) 769-3434
F (850) 769-6121

South Walton County Mosquito
Control District
Attn: Executive Director
774 N Co Hwy 393
Santa Rosa Beach, FL 32459

Fed. I.D. No: 63-0259798

Invoice Date: April 17, 2026
Invoice Number: 460949

Amy E. Myers

INVOICE TOTAL DUE \$ 2,190.00

36694 **South Walton County Mosquito Control District**
227912 **General Representation**
 Email invoices to: chenderson@swcmcd.org

Professional Services Rendered Through March 31, 2026

TOTAL FEES THIS INVOICE	2,190.00
TOTAL AMOUNT DUE	\$ 2,190.00

36694
227912

South Walton County Mosquito Control District
General Representation
Email invoices to: chenderson@swcmcd.org

PROFESSIONAL SERVICES RENDERED:

<u>DATE</u>	<u>TIMEKEEPER</u>	<u>NARRATIVE</u>	<u>HOURS</u>	<u>AMOUNT</u>
03/02/2026	AEM	Email from and to Cammie Henderson re employee issue.	0.20	60.00
03/03/2026	AEM	Email to Director and Commissioners re notice of Canut suit filing. Email from Cammie Henderson re new EEOC Charge from Canut. Review Retaliation complaint, email to Darrin Dunwald and Cammie Henderson.	0.70	210.00
03/04/2026	AEM	Email to Cammie Henderson re Canut's second EEOC charge.	0.20	60.00
03/05/2026	AEM	Telephone conference Darrin Dunwald and Cammie Henderson re employee matters.	0.50	150.00
03/09/2026	AEM	Email from Cammie Henderson re board meeting agenda prep.	0.10	30.00
03/10/2026	AEM	Email from and to Darrin Dunwald re HJR 203. Briefly review legislation.	0.30	90.00
03/16/2026	AEM	Receive and review correspondence re Canut suit, service of process.	0.10	30.00
03/17/2026	AEM	Receive and briefly review correspondence re Director contract.	0.10	30.00
03/17/2026	WAR	Review Director's contract with Commissioner questions and respond to SWMCD.	0.20	60.00
03/19/2026	AEM	Receive recap of Board meeting, actions on agenda items. Telephone from Director.	0.40	120.00
03/19/2026	WAR	Prepare for and attend March Board meeting.	2.00	600.00
03/23/2026	AEM	Receive and review correspondence re Canut discrimination complaint, EEOC claim status. Telephone call and to Bill Ritzmann re coverage, assignment of defense. Email to and from Bill Ritzmann re No Determination letter on first claim, no further action report on second claim, assignment of defense.	0.50	150.00
03/24/2026	AEM	Receive and review correspondence re assignment of Canut defense.	0.20	60.00
03/25/2026	AEM	Email from Rob Sniffen re Canut litigation defense.	0.10	30.00
03/25/2026	AEM	Receive and review certified letter from Sarah Stewart.	0.20	60.00

36694
227912

South Walton County Mosquito Control District
General Representation
Email invoices to: chenderson@swcmcd.org

<u>DATE</u>	<u>TIMEKEEPER</u>	<u>NARRATIVE</u>	<u>HOURS</u>	<u>AMOUNT</u>
03/26/2026	AEM	receive and review correspondence re service of Canut suit.	0.20	60.00
03/30/2026	AEM	Email and telephone conference from and to Darrin Dunwald re response to S. Stewart letter.	0.30	90.00
03/30/2026	AEM	Telephone conference Darrin Dunwald re Canut defense. Email to and from Rob Sniffen re meeting with Chair and Director to discuss defense strategy.	0.30	90.00
03/31/2026	AEM	Telephone to Darrin Dunwald re Stewart demand, Canut suit, Board requests.	0.70	210.00
TOTAL FEES			7.30	\$ 2,190.00

TOTAL AMOUNT DUE FOR THIS INVOICE \$ 2,190.00

OPERATIONS REPORT



SOUTH WALTON COUNTY MOSQUITO CONTROL DISTRICT

Operations Report April 2026

MONTHLY VALUES

ON HAND

ADULTICIDE

PRODUCT	MONTHLY OUTPUT	UNIT	UNIT VALUE	MONTHLY \$ VALUE	MONTHLY INVENTORY	INVENTORY \$\$
PERMASEASE 3-15	22.5	GAL	\$46.84	\$1,053.90	240	\$11,241.60
FYFANON ULV	17.9	GAL	\$80.49	\$320.41	130	\$10,463.70
TOTAL				\$1,374.31	TOTAL	\$21,705.30

LARVICIDE

LARVICIDES	MONTHLY OUTPUT	UNIT	UNIT VALUE	MONTHLY \$ VALUE	MONTHLY INVENTORY	INVENTORY \$\$
ALTOSID P35	120	POUND	\$20.25	\$2,430.00	1,480	\$29,970.00
ALTOSID XR	14,923	EACH	\$4.06	\$60,587.38	137	\$556.22
VECTOBAC WDG	0	POUND	\$45.58	\$0.00	0	\$0.00
VECTOLEX FG	0	POUND	\$6.26	\$0.00	0	\$0.00
COCO BEAR	10	OUNCE	\$0.15	\$1.53	2,424	\$370.14
VECTOLEX WDG	0	POUND	\$73.13	\$0.00	0	\$0.00
FOURSTAR BTI CRG	0	POUND	\$16.50	\$0.00	8,400	\$138,600.00
METALARV WSP	22	POUND	\$2.50	\$55.00	558	\$1,395.00
NATULAR G30	0	POUND	\$18.91	\$0.00	0	\$0.00
NATULAR XRT	0	EACH	\$5.51	\$0.00	0	\$0.00
VECTOMAX FG	67	EACH	\$10.53	\$705.51	1373	\$14,457.69
Duplex-G	0	POUND	\$16.90	\$0.00	0	\$0.00
TOTAL			TOTAL	\$63,779.42	TOTAL	\$185,349.05

HERBICIDE

AQUAMASTER	0	OZ	\$0.21	\$0.00	3840	\$806.40
SURF AC	0	OZ	\$0.10	\$0.00	4,912	\$491.20
LESCO 3WY	0	OZ	\$0.90	\$0.00	685	\$616.50
TOTAL				\$0.00	TOTAL	\$1,914.10
TOTAL				\$65,153.73	TOTAL	\$208,968.45

OTHER SERVICES

SERVICE REQUEST	18					
DITCH REQUEST	0					
FISH REQUEST	0					
SPRAY MISSIONS	7					
LARVICIDE MISSION	0					
UAS FLIGHTS	3					

Inspected/ treated 15,931 storm drains in nine working days.

Hired new entomologist

Continued cattail removal at Walton Way

COMMENTS

Spring has been beautiful, but April was notably dry (figure 1). This is a cause for concern, as mosquitoes tend to concentrate in the limited areas that receive moisture from infrequent rainfall. When egg-laying is focused within these few wet locations, vector mosquito populations can become highly concentrated, increasing the potential for localized arbovirus transmission. Compounding this issue, migratory birds, which can carry these viruses, also gather around these same wet areas. Together, these components can elevate the risk of disease activity.

For now, however, the dry conditions have kept mosquito activity relatively low. Our counts remain at or below average (Figure 2). We have detected only one infected sentinel chicken so far this year, in April. By comparison, last year’s first positive occurred in May (figure 3). Detecting a few positive (“hot”) chickens between March and May is not unusual.

Eastern Equine Encephalitis (EEE) typically emerges gradually at the start of the warm-season mosquito cycle, often peaking around June (figure 3). This is usually followed by a transition toward increased West Nile virus (WN) activity later in July, as its primary vector populations grow and shifts in bird migration patterns occur.

As temperatures continue to rise and precipitation increases, mosquito populations are expected to follow suit. Warm-weather species are already beginning to appear. Ideally, the rainfall observed at the end of April marks the beginning of a shift away from the recent dry conditions—provided it remains within a manageable range.

Average Temperature and Rainfall Totals Through March and April 2026

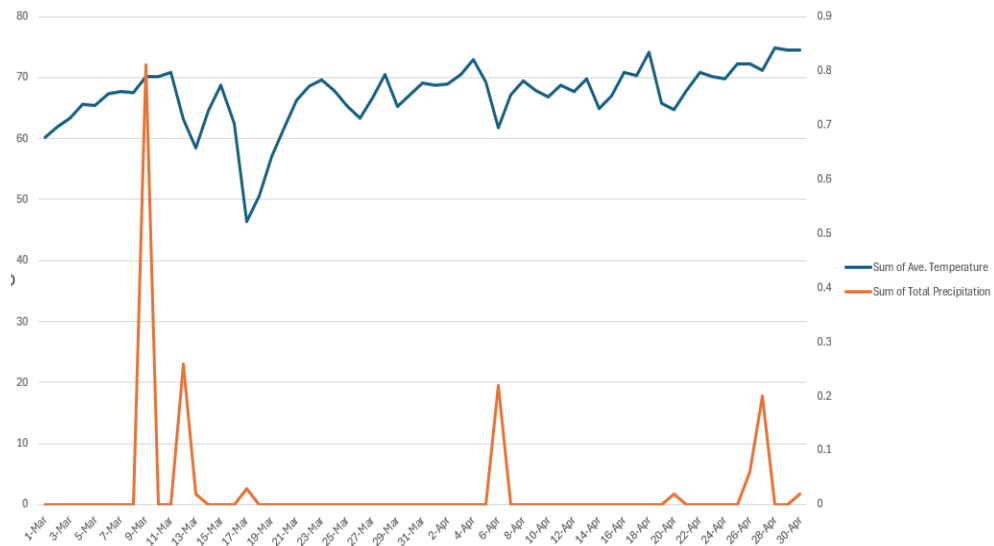

Figure 1.

Average Counts per Trap Night for All Species.

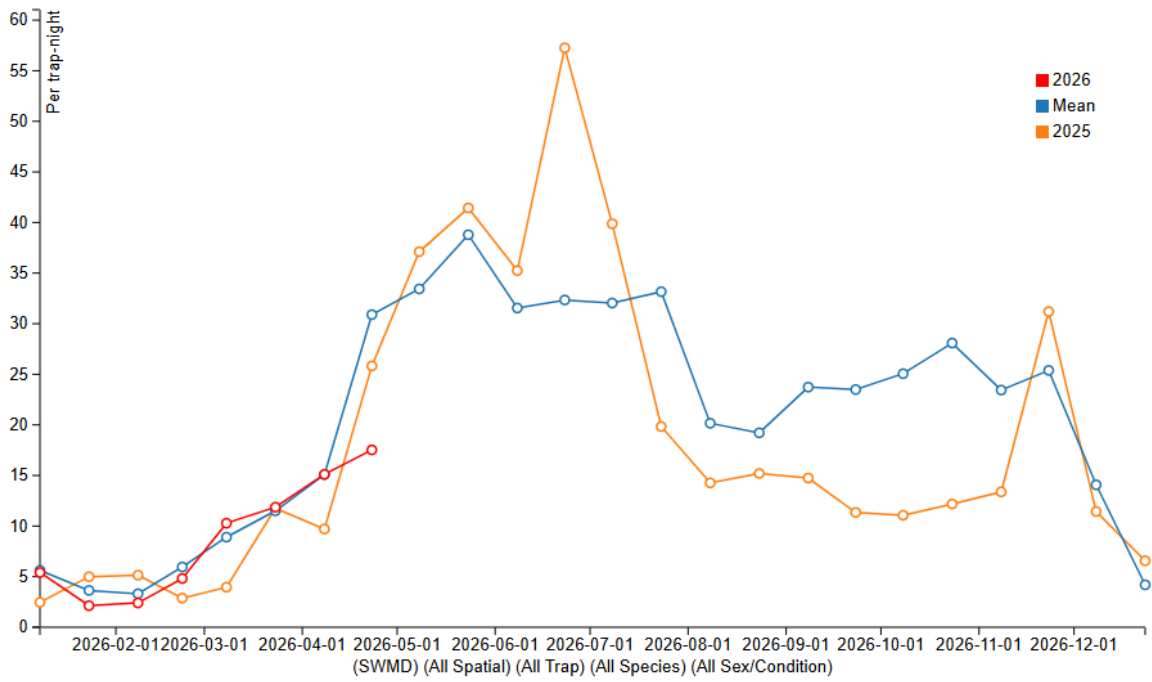

Figure 2.

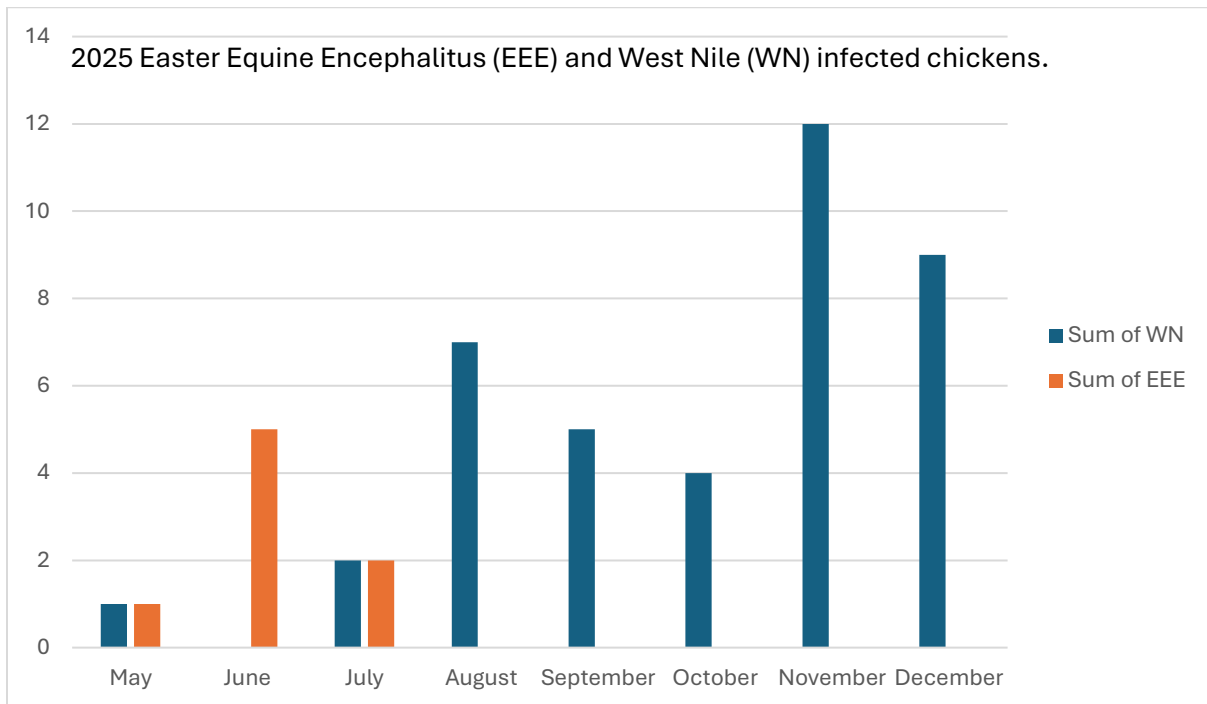

Figure 3.

NEW BUSINESS UPDATE



